

Other products from West



Single Loop Temperature Controllers



Multi-Loop Temperature Controllers



Limit Controllers



Indicators



Absolute and incremental encoders



Counters & Timers



A range of sensors



Recorders



Thyristors

The 8800 series Process Controllers and Profilers

8800 series



...setting a new standard in advanced control

West Instruments

Authorised distributors: **Ward Industries Limited**

Tel: +44 (0) 1933 624963

Fax: +44 (0) 1933 625458

e-mail: info@wardindustries.co.uk

Web: www.wardindustries.co.uk



West Instruments is a division of Danaher (UK Industries) Ltd. A member of the Danaher Corporation.

Available From:



Why the 8800 & 8840?

Because they are the **best value fully featured** controllers on the market

The 8800 series is a new advanced range from West Instruments, designed to ensure ease of use in demanding applications. Just look at all the features they offer:



- **Front Comms Port and Configurator Software**
- **Two Universal Inputs (3rd optional)**
- **Valve Control with/without Feedback**
- **Fast Sample Rate (100 ms)**
- **Maintenance manager and error list**
- **Self-Tuning to the setpoint without oscillation**
- **High visibility display shows plain text or bargraphs**
- **Up to 16 programs with 16 segments each***
- **4 control (event) tracks***

* 8840 Profiler only

- ▶ Process Controller (8800) and Profiler (8840) versions available
- ▶ Universal Linear/Relay/SSR output versions for reduced stocks
- ▶ Two freely configurable analogue outputs, e.g. as process value retransmit
- ▶ Customer-specific Linearisation for all sensors
- ▶ Settings can be locked via password and internal switch for high security
- ▶ Extended temperature range up to 60 °C allows mounting close to the process
- ▶ Easy 2-point or offset measurement correction
- ▶ Monitoring of heater current and output circuit
- ▶ Emergency operation after sensor break via the "output hold" function
- ▶ Logical combination of digital outputs, e.g. for general alarm
- ▶ Optional RS 422/485 Modbus RTU interface
- ▶ Optional built-in transmitter power supply
- ▶ Splash-water proof front (IP 65)
- ▶ O²-measuring with high impedance input (not with 8840)

APPLICATIONS

8800

Furnaces and Ovens
Burners and Boilers
Plastics Processing
Driers
Heat Treatment Plants
Thermal Oil Systems

8840

Chamber Ovens
Melting and Pot Furnaces
Climatic and Test Chambers
Driers
Heat Treatment Plants
Test Beds
Textile Treatment (dyeing)
Glass Industry (tempering)

DESCRIPTION

Our new 8800 series of controllers offers you the best in advanced process control, ensuring the quality, flexibility and value for money you have come to expect from West.

The 8800 Process Controller and 8840 Profiler provide a choice of simple 2-point (on/off) control, continuous PID control, or 3-point stepping control (valve motor drive). The process value signal is connected via a universal input. A supplementary analogue input can be used for heater current measurement, as an external setpoint input, or for position feedback measurement of motorised stepping controllers. The optional 3rd input is a universal input that can be used for several functions, e.g. temperature dependent setpoint correction or differential control.

Every 8800 and 8840 comes fitted with four process outputs - either relays or up to 2 universal outputs that can be used for operating a solid-state relay, a linear current/voltage output or to power a two-wire transmitter. Optionally there are two additional opto coupler outputs.

Front Comms Port and Configurator

You can control parameter adjustment in seconds with the 8800 series. A convenient front comms port provides instant and easy set-up via the configurator on your PC without removing the instrument from the panel.

Furthermore, our "simulator" allows you to conduct comprehensive off-line tests, ensuring safe operation for your application.



Valve Control with or without Feedback

The 8800 and 8840 has an option of open and close outputs for valve control with two inputs for valve feedback and remote setpoint.

Maintenance Manager and error list

The maintenance manager ensures smooth operation of any process. It performs a number of preventative maintenance tasks, such as a reminder for replacement of actuators or other equipment; detection of SSR faults and heating element failure; motor-valve monitoring (on the 8800 only) and detection of an open circuit control loop or detection of transient faults.

Self-tuning during start-up and to setpoint

This function determines the optimum settings for accurate control without overshoot. With three-point controller configuration, the "cooling" parameters are determined separately, thus ensuring an optimum match to the process. At the push of a button the 8800/8840 determines the best control parameters at the actual setpoint. This function does not require oscillation, and performs a minimal deviation of the process value.

Display and Operation

The "day & night" display of the 8800/8840 is characterised by particularly high contrast in both dark and bright surroundings. The status fields show operating conditions, control mode, and error messages clearly. The display is in plain text and can show various process values numerically or as a bargraph.

Password protection

If required, access to the various operating levels can be protected with a password. Similarly, access to a complete level can be blocked.

8800 Series

TECHNICAL DATA

INPUTS

Input	Used for
INP1	x 1 (process value)
INP2	Heater current, ext. remote set-point or ext. correction, position feedback Yp, 2nd process value x2, ext. correcting variable Y.E, input for additional limit signalling and indication
INP3 (option)	as for INP2
di1	Programme run/stop, programme reset* Operation disabled, controller off, auto/manual function, reset of stored alarms, switch-over to ...
di2	second set-point SP.2, external set-point S.P.E,
di3 (option)	fixed correcting variable Y2, ext. correcting variable Y.E, manual operation, parameter set 1 ↔ 2, process value INP1 ↔ X2

* 8840 only

PROCESS VALUE INPUT INP1

Resolution:	> 14 bit
Decimal point:	0 to 3 decimals
Digital input filter:	adjustable 0.0 to 100.0 s
Scanning cycle:	100 ms
Measured value correction:	2-point or offset correction
Special (-linearisation):	16 segments
Standard table:	temperature sensor KTY 11-6

Thermocouples (Table 1)

Input impedance:	1 MΩ
Effect of source resistance:	1 μV/Ω

Cold junction compensation

Max. additional error	± 0.5 K
-----------------------	---------

Sensor break monitoring

Sensor current:	≤ 1 μA
Operating sense configurable (see page 8)	

Resistance Thermometer

Connection:	3-wire
Lead resistance:	max. 30Ω
Input circuit monitor:	Break and short circuit

Current and voltage signals

Span start, end of span:	anywhere within measuring range
Scaling:	selectable -1999 to 9999
Linearisation:	16 segments, adaptable with Configurator
Decimal point:	adjustable
Input circuit monitor:	12.5% below span start (2mA, 1V)

The measuring range 0 to 100mV can be used together with the special linearisation function for connection of thermocouples with external temperature compensation.

SUPPLEMENTARY INPUT INP2

Resolution:	>14 bit
Sample Rate:	100 ms
<i>Heating current measurement via current transformer</i>	
Measuring range:	0 to 50 mA AC
Scaling:	adjustable -1999 to 0,000 to 9999 A

Current measurement range

Input resistance	approx. 120 Ω
Span:	configurable within 0 to 20mA
Scaling:	adjustable -1999 to 9999
Input circuit monitor:	12.5% below span start (2mA for 4-20mA range)

Potentiometer

Ranges see Table 2	
Connection:	2-wire
Lead resistance:	max. 30 Ω
Input circuit monitor:	Break

SUPPLEMENTARY INPUT INP3 (OPTION)

Resolution:	> 14 bit
Sample Rate:	100 ms
Technical data as for INP1 except the 10V range.	

CONTROL INPUTS DI1, DI2

Configurable as direct or inverse switch or push-button
Connection of a potential-free contact suitable for switching "dry" circuits.

Switched voltage:	5 V
Switched current:	100 μA

CONTROL INPUTS DI2, DI3 (OPTION)

The digital input di2 located on the A-card and di2 located on the option card are or-linked.

Configurable as switch or push-button
Optocoupler input for active triggering

Nominal voltage:	24 V DC, external
Current sink (IEC 1131 Type 1)	
Logic "0":	-3 to 5 V
Logic "1":	15 to 30 V
Current requirement:	approx. 5 mA

TRANSMITTER SUPPLY U_T (OPTION)

Output:	22 mA / 18 V
---------	--------------

If the universal outputs OUT3, 4 are used there may be no external galvanic connection between measuring and output circuits

Table 1 Thermocouple Ranges

Thermocouple		Range		Accuracy	Resolution (∅)
B ⁽¹⁾	PtRh-Pt%	0(400) to 1820°C	32(752) to 3308°F	≤ 3°K	0.3K
C	W5%Re-W2%Re	0 to 2315°C	32 to 4199°F	≤ 2°K	0.4K
D	W3%Re-W25%Re	0 to 2315°C	32 to 4199°F	≤ 2°K	0.4K
E	NiCr-CuNi	-100 to 1000°C	-148 to 1832°F	≤ 2°K	0.1K
J	Fe-CuNi	-100 to 1200°C	-148 to 2192°F	≤ 2°K	0.1K
K	NiCr-Ni	-100 to 1350°C	-148 to 2462°F	≤ 2°K	0.2K
L	Fe-CuNi (DIN)	-100 to 900°C	-148 to 1652°F	≤ 2°K	0.1K
N	Nicrosil/Nisil	-100 to 1300°C	-148 to 2372°F	≤ 2°K	0.2K
R	PtRh-Pt 13%	0 to 1760°C	32 to 3200°F	≤ 2°K	0.2K
S	PtRh-Pt 10%	0 to 1760°C	32 to 3200°F	≤ 2°K	0.2K
T	Cu-CuNi	-200 to 400°C	-328 to 752°F	≤ 2°K	0.05K
	special	-25 to 75mV		≤ 0.1%	0.01%

⁽¹⁾ Reduced accuracy below 400°C

Table 2 Resistance Transducers

Type	Sensor current	Range		Accuracy	Resolution (∅)
Pt100	0.2mA	-200 to 850°C	-328 to 1562°F	1°K	0.1K
Pt1000					
KTY 11-6*		-50 to 150°C	-58 to 302°F		0.05K
special		0 to 4500Ω**		≤ 0.1%	0.01%
special		0 to 450Ω**			
Potentiometer		0 to 160Ω**			
Potentiometer		0 to 450Ω**			
Potentiometer		0 to 1600Ω			
Potentiometer	0 to 4500 Ω				

* corresponds to special 0 to 4500Ω

** lead resistance included

Table 3 Current and Voltage

Range	Input Resistance	Accuracy	Resolution (∅)
0-10V	110 KΩ	0.1%	0.6mV
0-100mV	1MΩ	0.1%	6 μV
0-20mA	20Ω	0.1%	1.5 μA

OUTPUTS

Output	Used for
OUT1, 2 (relays)	Control output heating/cooling or Open/Close, limit contacts, alarms*. For 8840 only - control (event) tracks, program end, operator call
OUT3, 4 (relays or logic)	as OUT1 and OUT2
OUT3, 4 (linear)	Control output, process value, measured values INP1/2/3, set-point, control deviation, position feedback Yp, transmitter supply 13V/22mA
OUT5 OUT6 (optocoupler)	as OUT1 and OUT2

OPTION

* All logic signals can be OR-linked

RELAY OUTPUTS OUT1 TO OUT4

Contacts:	Potential-free changeover contact
Max. contact rating:	500 VA, 250 VAC, 2A at 48 to 62 Hz, resistive load
Min. contact rating:	6 V, 1 mA AC/DC
Operating life (electric):	800.000 duty cycles with max. rating

Note:
If the relays operate external contactors, these must be fitted with RC snubber circuits to manufacturer specifications to prevent excessive switch-off voltage peaks.

OUT3, OUT4 AS UNIVERSAL OUTPUT

Galvanically isolated from the inputs.

Freely scalable	
DA-converter limiting frequency T_{90} :	50 ms
Limiting frequency of the complete continuous controller:	> 2 Hz
Resolution:	11 bit

Current output

0/4 to 20 mA, configurable.	
Signal range:	0 to approx. 22 mA
Load:	$\leq 500\Omega$
Load effect:	none
Resolution:	$\leq 22 \mu A$ (0.1%)
Error:	$\leq 40 \mu A$ (0.2%)

Voltage output

0/2 to 10V, configurable	
Signal range:	0 to 11 V
Load:	$\geq 2 k\Omega$
Load effect:	none
Resolution:	$\leq 11 mV$ (0.1%)
Error:	$\leq 20 mV$ (0.2%)

OUT3, OUT4 used as transmitter supply

Output:	22 mA / $\geq 13 V$
---------	---------------------

OUT3 used as logic output

Load $\leq 500\Omega$	0/ $\leq 20 mA$
Load $\geq 500\Omega$	0/ > 13 V

OUTPUTS OUT5, OUT6 (OPTIONAL)

Galvanically isolated opto-coupler outputs.
Grounded load: common positive control voltage.
Output rating: 18 to 32 VDC; =70 mA
Internal voltage drop: =1 V with I_{max}
Protective circuit: built-in against short circuit, overload, reversed polarity..

DIMENSIONS (mm)

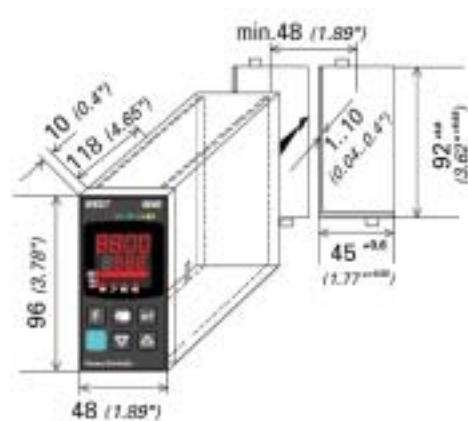

GALVANIC ISOLATIONS

- Safety isolation
- Functional isolation

Mains supply	Process value input INP1 Supplementary input INP2 Optional input INP3 Digital inputs di1, di2
Relay OUT1	RS422/485 interface
Relay OUT2	Digital inputs di2, 3
Relay OUT3	Universal output OUT3
Relay OUT4	Universal output OUT4
	Transmitter supply U_T
	OUT5, OUT6

Electrical Connections

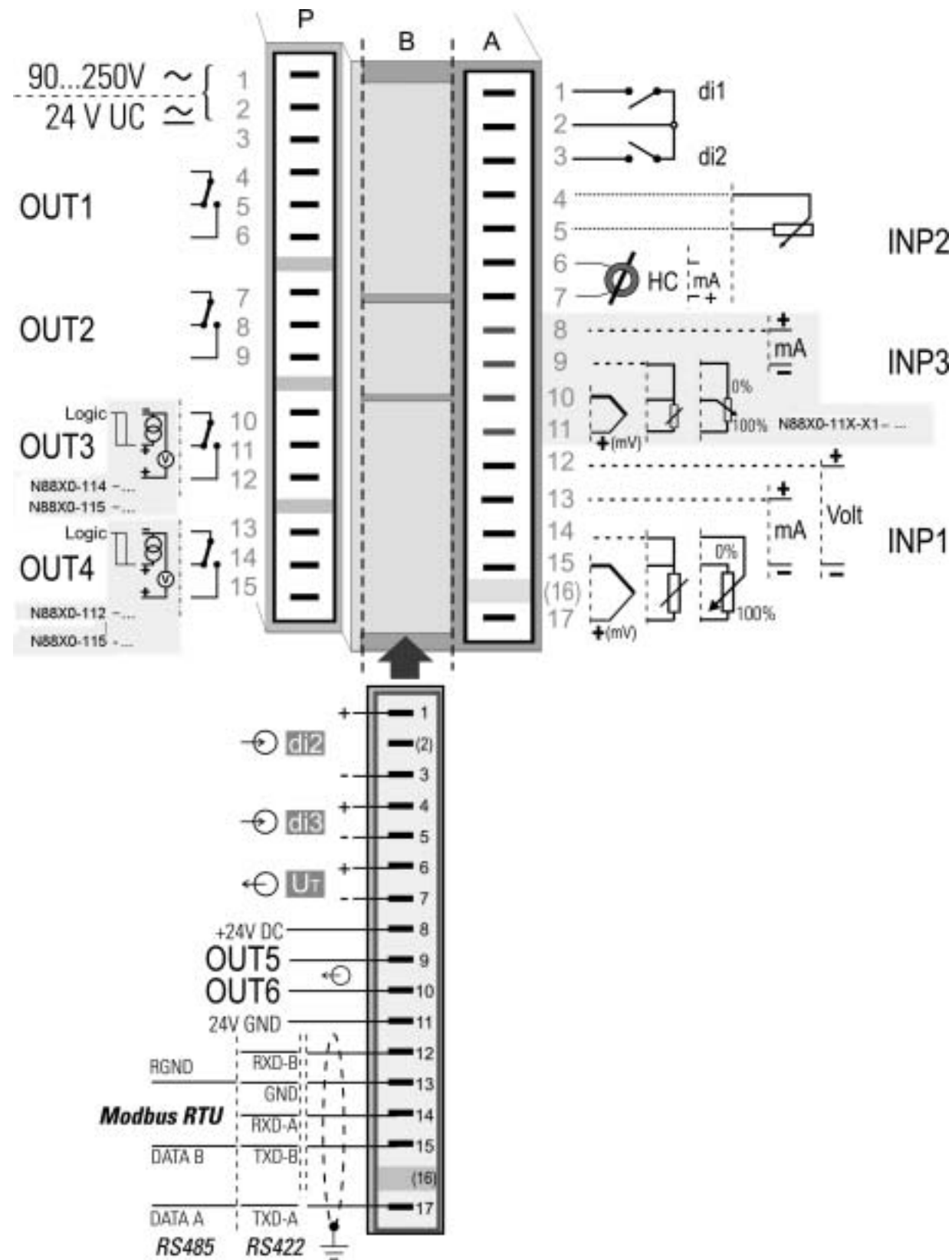

FUNCTIONS

Control behaviour

- ON/OFF control
- PID controller (2-point and continuous)
- Delta / Star / Off or 2-point controller with switch over from partial to full load
- 2 x PID (heating/cooling)
- 3-point stepping controller (valve motor drive) with or without position feedback
- Continuous controller with internal positioner (stepping controller)

Two parameter sets for manual gain scheduling
Self-tuning control parameters or adjustable manually via front keys or configurator.

Behaviour with 2- and 3-point controllers

- **Standard behaviour:**
For precise matching of the required output value at the output signal limits, the controller changes the cycle times for heating and cooling automatically and continuously.
- **With constant cycle times:**
The length of the shortest heating and cooling pulse is adjustable.
- **Water cooling linear (heating=standard): (8800 only)**
To ensure a sufficient cooling effect, the cooling function starts only after reaching an adjustable temperature value. The pulse length is also adjustable and remains constant for all output values.
- **Water cooling nonlinear (heating=standard): (8800 only)**
The general function is described above but the controller additionally takes in consideration that the water cooling is usually much stronger than the heating (thus preventing unfavourable behaviour when changing from heating to cooling).

Set-point functions

- Adjustable set-point gradient (rate) 0.01 to 9999 °C/min
- Set-point control
- Set-point/cascade control
- Set-point/cascade control with external correction
- Programme control (8840 only)
- Programme control with external correction (8840 only)

Process value calculation

- Standard ($x_{eff} = INP1$)
- Ratio ($INP1/X2$)
- Difference ($INP1-X2$)
- Max ($INP1, X2$)
- Min ($INP1, X2$)
- Mean value ($INP1, X2$)
- Switch-over between $INP1$ and $X2$

Behaviour with sensor break or short circuit:

- Control outputs switched off
- Switch-over to a safe output value
- Switch-over to a mean output value

8840 Profiler Additional Features

Programs:	8 or 16 (dep. on version)
Control tracks:	4 events
Segments:	16 each
Types of segments:	ramp (setpoint and time) ramp (setpoint and ramp) dwell segment (with limit monitoring suppression) Step segment (with limit monitoring suppression) End segment

All types of segments can be combined with "wait at the end and operator call"

Time base:	configurable hrs:mins or mins:secs
Max. segment duration:	9999 hours = 1 year 51 days
Max. prog. duration:	16 x 9999 hrs = >18 years
Ramp	0.01°C/hr (/min) to 9999°C/hr (/min)

Program Names:	8 characters, adjustable with Configurator
Bandwidth control	Upper and lower bandwidth configurable for each program

SPECIAL FUNCTIONS

Modbus Master

The 8800 and 8840 can be configured as Modbus Master. This enables them to transmit user-specified signals or parameters cyclically to all connected Slave controllers. For example, the following applications are possible:

- Set-point shifting relative to the set-point adjusted in the Slave (see picture)
- Matching of control parameters, limit contacts, etc.
- Limiting the output value (override control OVC)

DAC ensures operational safety (8800 only)

Digital Actuator Control monitors the most important functions of the actuator and is able to detect problems long before they cause large control deviations. Typical disturbances are a blocked actuator, a defective motor or capacitor and all related problems with an actuator.

The DAC function is available for three-point stepping (valve motor drive) controllers with potentiometer position feedback measured via $INP3$.

LIMIT SIGNALLING FUNCTIONS

Max., Min. or Max./Min. monitoring with adjustable hysteresis.

Signals which can be monitored:

- Process value
- Control deviation
- Control deviation with suppression during start-up or set-point changes
- Effective set-point
- Output signal Y
- Input values of $INP1, INP2, INP3$
- Difference $INP1 - X2$. This function allows to detect aged thermocouples.

Functions

- Input signal monitoring
 - Input signal monitoring with latch (reset via front key or digital input)
 - Rate of change monitoring (/min)
 - Adjustable discriminator time of 0 to 9999 seconds
- Several limit signals or alarms can be OR-linked before being output.
Applications: Release of a brake with motor actuators, general alarms, etc.

ALARMS

Heating current alarm

- Overload and short circuit
 - Open circuit and short circuit
- Limit value adjustable 0 to 9999 A

Control loop alarm

Automatic detection if there is no response of the process to a change of output value.

Sensor break or short circuit

Depending on selected input type, the input signal is monitored for break and short circuit.

MAINTENANCE MANAGER

Display of error signals, warnings, and latched limit messages in the error list.
Signals are latched, and can be reset manually.

Modbus Master function sends the setpoint to the slave controllers and 8800/8840 with/without offsets

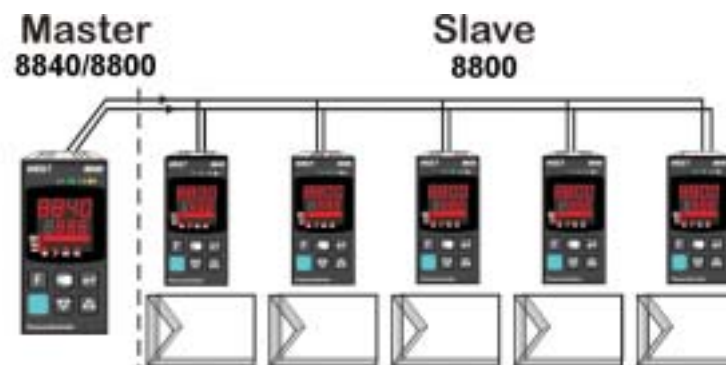

Display and operation - 8800 Process Controller:



Display and operation - 8840 Profiler:



OPERATION AND DISPLAY

Display

Multi-function Day & Night display with red backlighting (adjustable)
 Process value: 4 x 7 segment 10,5 mm
 Lower display: 4 x 7 segment 7,8 mm
 Text display: 8-character dot matrix used as numeric or bargraph display

Operating functions

The functions of the **■** key for the 8800 and 8840 and the **F** key for the 8840 are configurable:

Function	■	F
Remote (no front operation)		X
SP.2 (2nd setpoint)		X
Y.2 (2nd output value)	X	X
SP.E (external setpoint)	X	X
Manual operation	X	X
C.OFF (controller function off)	X	X
Lock of manual key		X
Reset of latched limits and error list	X	X
Parameter set 1 ↔ 2		X

Several functions can be combined e.g. SP.2 and parameter set switch-over (gain scheduling) with only one key.

POWER SUPPLY

Depending on version:

AC SUPPLY

Voltage: 90 to 260 VAC
 Frequency: 48 to 62 Hz
 Power consumption approx. 8 VA

UNIVERSAL SUPPLY 24 V UC

AC voltage: 20.4 to 26.4 VAC
 Frequency: 48 to 62 Hz
 DC voltage: 18 to 31 V DC
 Power consumption: approx. 8 VA (W)

BEHAVIOUR WITH POWER FAILURE

Configuration, parameters, and adjusted set-points, control mode:
 Non-volatile storage in EEPROM

FRONT COMMS PORT

Connection of PC via PC adaptor (see "Accessories"). The configurator is used to configure, set parameters, and operate the 8800 and 8840.

BUS INTERFACE (OPTION)

RS 422/485 INTERFACE

Galvanically isolated
 Physical: RS 422/485
 Protocol: Modbus RTU
 Transmission speed: 2400, 4800, 9600, 19.200 bits/s
 Address range: 00 to 99
 Number of controllers per bus: 32
 Repeaters must be used to connect more controllers.

ENVIRONMENTAL CONDITIONS

Protection modes

Front panel: IP 65
 Housing: IP 20
 Terminals: IP 00

Permissible temperatures

Operating temperature for full specified accuracy: 0 to 55°C
 Operating temperature: -20 to 65°C
 Storage temperature: -40 to 70°C
 Warm-up time: < 15 minutes
 Temperature effect: <100ppm/K

Humidity

75% yearly average, no condensation

Shock and vibration

Vibration test Fc (DIN 68-2-6)
 Frequency: 10 to 150Hz
 Unit in operation: 1g or 0.075mm
 Unit not in operation: 2g or 0.15mm
 Shock test Ea (DIN IEC 68-2-27)
 Shock: 15g
 Duration: 11ms

Electromagnetic compatibility

Complies with EN 61 326-1
 • Complies with the immunity requirements for continuous, unattended operation
 • Complies with the emission requirements class B for rural areas
 • Surge disturbances may increase the measurement error and lead to error messages

GENERAL

Housing

Material: Makrolon 9415 flame-retardant
 Flammability class: UL 94 VO, self extinguishing

Plug-in module, inserted from the front

Safety Tests

Complies with EN 61010-1 (VDE 0411-1)
 Over voltage category II
 Contamination class 2
 Working voltage range 300 VAC
 Protection class II

Certifications

UL Certification (only available with screw terminal version)

For 8800 only:
 Type test to DIN 3440
 Can therefore be used in:

- Heat generation plants with outflow temperatures up to 120°C to DIN 4751
- Hot-water plants with outflow temperatures above 110°C to DIN 4751
- Thermal transfer plants with organic transfer media to DIN 4754
- Oil-heated plants to DIN 4755

Electrical Connections

- Screw terminals for conductor cross-section from 0.5 to 2.5mm

Mounting

Panel mounting with two fixing clamps at top/bottom or left/right
 Close mounting possible
 Mounting position: Not critical
 Weight: 0.27kg (9.52 oz)

Accessories supplied with unit

Operating instructions
 2 fixing clamps

ACCESSORY EQUIPMENT

Front Comms Port (Engineering Tool)

PC-based Program for configuring, setting parameters and operating the 8800 and 8840 controllers. Moreover, all the settings are saved, and can be printed on demand. Depending on version, a powerful data acquisition module is available, complete with trend graphics.

Visibility Mask

The configurator can be used to hide parameters in the instrument. Thus, only allowed parameters can be changed on site. Safety relevant parameters are invisible!

Simulation

The built-in simulation serves to test the controller settings, but can also be used for general training and observing the interaction between controller and control loop.

Configurations that can only be implemented via the configurator (not via the front-panel keys):

- Customer-specific linearisations
- Enable "forcing" for inputs/outputs
- Adjustment of limits for operating hours and switching cycles
- Switch-over to 60Hz mains frequency
- Master/slave configuration
- Disable operator actions and operating levels, plus password definition
- Prevent automatic optimisation of cycle times T1, T2

Hardware and Software requirements:

Windows 95/98/NT/2000/XP
 PC adaptor (see "Accessories") is required for connecting the controller

Configurator, versions and functionality

Functionality	Mini	Basic	Expert
Parameter and configuration setting	yes	yes	yes
Controller and control loop simulation	yes	yes	yes
Download: writes a configuration to the controller	yes	yes	yes
Online mode / visualisation	SIM only	yes	yes
Creation of user defined linearisations	SIM only	yes	yes
Configuration of extended operating level	SIM only	yes	yes
Upload: reads a configuration from the controller	SIM only	yes	yes
Basic diagnostic function	SIM only	yes	yes
File, save engineering data	no	yes	yes
Printer function	no	yes	yes
Online documentation, help system	no	yes	yes
Measurement correction (calibration procedure)	no	yes	yes
Program editor	SIM only	SIM only	yes
Data acquisition and trend function	SIM only	SIM only	yes

ORDER CODE

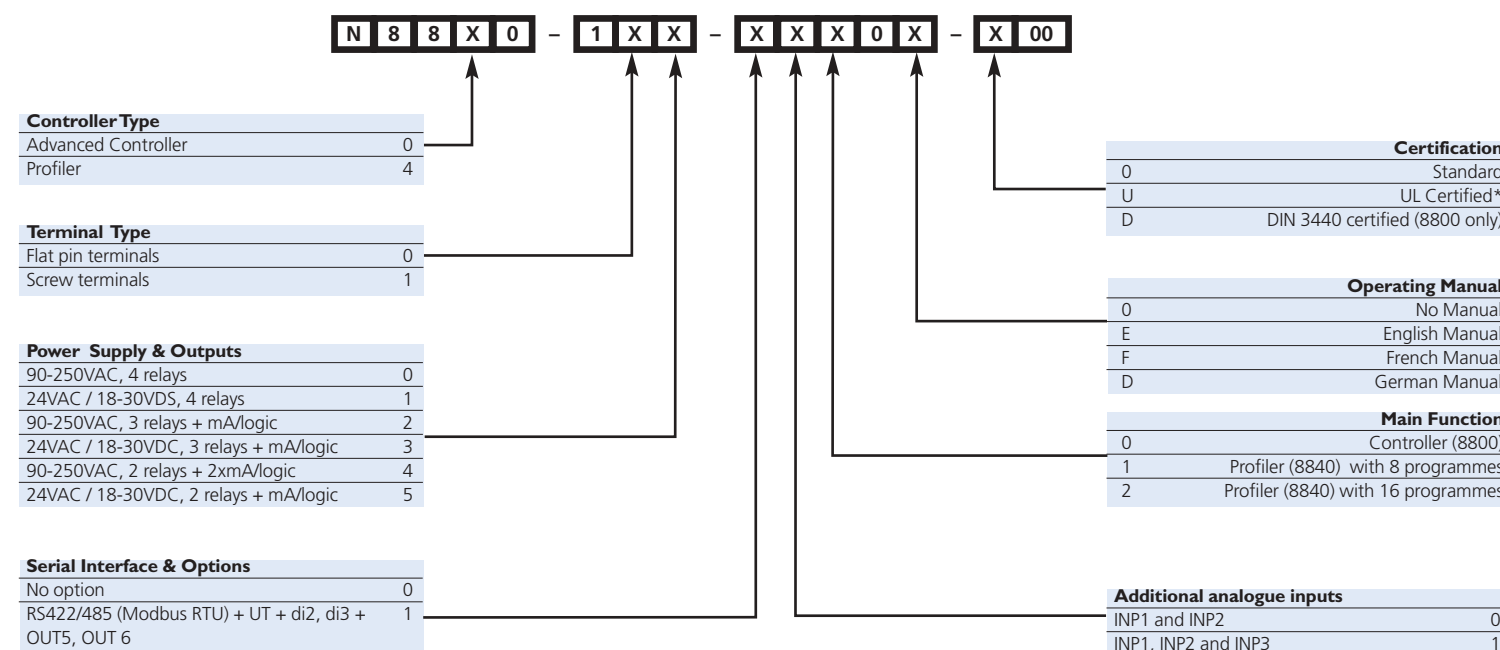

* UL certification only available with screw terminals, not flat pin

In accordance with our policy of continuous improvement, we reserve the right to change specifications from those shown in this document.

ACCESSORY PART NOS

Current converter 50A AC	9404-407-50001
PC adaptor for front comms port	9407-998-00002-069
DIN-rail adaptor	9407-998-00062-069
Dimension shields	4012-140-66041
Configurator - basic version	9407-999-11001
Configurator - expert version	9407-999-11011
Sub-D connector for flat-pin connectors	9407-998-07002-069
Sub-D connector for screw terminals	9407-998-00012-069