

**WEST 3700/3800
CONTROLLERS**

**Installation & Operating
Instructions**

Dynapar, Veeder Root, and Eagle Signal Brands:

Sales, Repair, and Application Support:
1675 Delany Rd.
Gurnee, IL. 60031
847-662-4150 Sales/Order Entry Fax
847-782-5277 Applications Support Fax
800-873-8731 Sales/Order Entry
800-234-8731 Applications Support

NorthStar Brand:

Sales, Repair, and Application Support:
1675 Delany Rd.
Gurnee, IL. 60031
847-782-5288 Sales/Order Entry Fax
847-782-5277 Applications Support Fax
800-326-6216 Sales/Order Entry
800-326-6216 Applications Support

Partlow, West, Rustrak, and LFE Brands:

Sales, Repair, and Application Support:
1675 Delany Rd.
Gurnee, IL. 60031
847-662-4150 Sales/Order Entry Fax
847-782-5277 Applications Support Fax
800-873-8731 Sales/Order Entry
800-866-6659 Applications Support

Please disregard all phone numbers and addresses in this manual. The phone numbers and address on this page are the correct phone number and addresses to use for sales, repair, and application support.



CAUTION: REFER TO MANUAL

THE INTERNATIONAL HAZARD SYMBOL IS INSCRIBED ADJACENT TO THE REAR CONNECTION TERMINALS. IT IS IMPORTANT TO READ THE MANUAL BEFORE INSTALLING OR COMMISSIONING THE UNIT.

**WEST INSTRUMENTS
LIMITED**

The Hyde, Brighton,
East Sussex
BN2 4JU
England.
Tel: +44 (0) 1273 606271
Fax: +44 (0) 1273 609990

**GULTON DIVISION
Veeder-Root SARL**

8 Place de la Loire
Silic 422
94583 Rungis CEDEX
France.
Tel: 33 (1) 46-87-09-81
Fax: 33 (1) 46-86-80-04

**WEST INSTRUMENTS
Unternehmensbereich
der Veeder-Root GmbH**

Zum Bahndamm 40
61200 Wolfersheim
West Germany.
Tel: (06036) 97 07-0
Fax: (06036) 97 07-15

**PARTLOW-WEST
COMPANY**

Two Campion Road
New Hartford, NY
13413
U.S.A.
Tel: (315) 797-2222
Fax: (315) 797-0403

WEST 3700/3800 CONTROLLERS

INSTALLATION AND OPERATING INSTRUCTIONS

IM-0033-B0

NOTE

Our policy is one of continued improvement and, subsequently, the information contained in this publication may differ in some respects from the instrument in question. Therefore, this document does not constitute an offer or part of an offer for sale.

Contents

Section	Title	Page
1	Introduction	1-1
1.1	Operator Controls and Indicators	1-1
1.2	Options and Variants	1-1
2	Installation	2-1
2.1	Unpacking Procedure	2-1
2.2	Panel-mounting a Standard Controller	2-1
2.2.1	Pre-requisites	2-1
2.2.2	Panel-mounting Procedure	2-1
2.3	Panel-mounting a Controller with a Remote Front Panel	2-2
2.3.1	Pre-requisites	2-2
2.3.1.1	Remote Front Panel	2-2
2.3.1.2	Controller	2-2
2.3.2	Panel-mounting Procedure	2-2
2.3.2.1	Remote Front Panel	2-2
2.3.2.2	Controller	2-2
2.3.3	Connecting the Controller to the Remote Front Panel	2-2
2.4	Removal of the Controller from its Housing	2-2
2.5	Replacement of the Controller in its Housing	2-3
2.6	Connections and Wiring	2-3
2.6.1	Mains (Line) Input	2-5
2.6.2	Thermocouple Input	2-5
2.6.3	Three-wire Resistance Temperature Detector (RTD) Input	2-6
2.6.4	DC Linear Inputs	2-6
2.6.5	Output 1 (Heat)	2-7
2.6.5.1	Relay Output 1 (Product Code --H10--)	2-7
2.6.5.2	SSR Drive Output 1 (Product Code --H50--)	2-7
2.6.5.3	DC Output 1 (Product Codes H21, H24, H61 & H64)	2-7
2.6.6	Output 2 (Cool)	2-8
2.6.6.1	Output 2 Relay (Product Code --C10--)	2-8

	Page	
2.6.6.2	Output 2 SSR Drive (Product Code --C50--)	2-8
2.6.6.3	DC Output 2 (Product Codes C21, C24, C61 or C64)	2-8
2.6.7	VMD Open Loop Output - Model 3800 Controllers Only	2-9
2.6.8	Alarm Output - Optional (Product Codes --C--46 to --C--51)	2-10
2.6.9	Remote Set Point Input - Product Codes X04(40), X05(40), X37(40) and X38(40)	2-10
2.6.9.1	Remote Set Point Input Selection	2-10
2.6.9.2	Remote Set Point Input	2-10
2.6.10	Recorder Output (Product Codes X12, X18, X19 and X20)	2-11
2.6.11	RS485-compatible Serial Communications Link	2-11
2.7	Inductive Loads; External Contactors and Mains-operated Relays	2-11
2.7.1	General Notes	2-11
2.7.2	An External Switch In Series With An External Inductive Load	2-12
3	Operating Instructions	3-1
3.1	Introduction	3-1
3.2	Displays (User Mode)	3-1
3.3	Front Panel Indicators	3-1
3.4	Front Panel Controls	3-2
3.5	Self-test Procedure	3-2
3.6	Normal Display	3-2
3.7	Set Point Adjustment	3-3
3.7.1	Set Point or (on Controllers with RSP Input) Local Set Point	3-3
3.7.2	Remote Set Point	3-3
3.8	Ramping Set Point	3-3
3.9	Manual Control	3-4
3.9.1	Entering and Leaving Manual Control	3-4
3.9.2	Manual Control Displays	3-4
3.10	Default Parameter Indication	3-5
3.11	Remote Control via the RS485-compatible Link	3-5
4	Setting-up Procedures	4-1
4.1	To Enter Set-up Mode	4-1
4.2	To Display And, If Required, Adjust a Parameter	4-1
4.3	Control Parameters	4-4
4.3.1	Set Point - SP/Local Set Point - LSP	4-4
4.3.2	Remote Set Point - rSP	4-4
4.3.3	Ramping Set Point Rate - rP	4-4
4.3.4	Output Power - OP	4-4
4.3.5	Proportional Band - Pb	4-4
4.3.6	Integral Time Constant - rSEt	4-4

Section	Title	Page
4.3.7	Derivative Time Constant - rAtE	4-5
4.3.8	Relative Gain - rCG	4-5
4.3.9	Overlap/Deadband - OL	4-5
4.3.10	On/OFF Differential - diF1, diF2 or diFF	4-5
4.3.11	Set Point Minimum and Set Point Maximum - SPhI & SPLo	4-5
4.3.12	Remote Set Point Scale Maximum - rSPH	4-5
4.3.13	Remote Set Point Scale Minimum - rSPL	4-5
4.3.14	Recorder Output Scale Maximum - roPH	4-5
4.3.15	Recorder Output Scale Minimum - roPL	4-6
4.3.16	Output 1 Power Limit - OPHI	4-6
4.3.17	Output 1 Cycle Time - Ct1	4-6
4.3.18	Output 2 Cycle Time - Ct2	4-7
4.3.19	Output 2 Value - Out2	4-7
4.3.20	Process Alarm Value - P_AL	4-7
4.3.21	Band Alarm Value - b_AL	4-7
4.3.22	Deviation Alarm Value - d_AL	4-7
4.3.23	Motor Travel Time - tr	4-7
4.3.24	Motor Switching Hysteresis - hYSt	4-7
4.3.25	Scale Range Decimal Point - rPnt	4-8
4.3.26	Scale Range Maximum - rhi	4-8
4.3.27	Scale Range Minimum - rLo	4-8
4.3.28	Auto Pre-Tune Enable/Disable - APt	4-8
4.3.29	Manual Control Enable/Disable - EnbL	4-8
4.4	Tuning the Controller Manually	4-9
4.4.1	Controllers Fitted with Output 1 Only	4-9
4.4.2	Model 3800 Controllers with VMD Open Loop Output	4-10
4.4.3	Controllers Fitted with Output 1 and Output 2	4-10
4.5	Tuning the 3800 Controller using Pre-tune and Self-tune	4-12
4.5.1	Using the Pre-Tune Facility	4-12
4.5.2	Using the Self-Tune Facility	4-12
4.6	Alarms	4-13
4.7	Leaving Set Up Mode	4-13
5	Operation via an RS485-compatible Serial Communications Link	5-1
5.1	RS485 Connections	5-1
5.2	Activating the Communications Link	5-1
5.3	RS485 Channel Selection	5-1
5.4	RS485 Operation	5-1
5.4.1	Character Transmission	5-1
5.4.2	Line Turn-Round	5-1
5.4.3	Communications Protocol	5-3

Section	Title	Page
5.4.4	Data Format	5-6
6	Range-changing and Re-configuration	6-1
6.1	Dismantling the Controller	6-1
6.1.1	Withdrawing the Controller from its Housing	6-1
6.1.2	Separating the PCBs (if an Options Board is Fitted)	6-1
6.2	Changing Input Ranges	6-4
6.2.1	Thermocouple Inputs	6-4
6.2.2	RTD Inputs	6-5
6.2.3	Linear Inputs	6-6
6.3	Changing the Action of Output 1	6-6
6.4	Output 2 and Alarm Outputs	6-6
6.5	DC Outputs (without X06 Option)	6-7
6.6	RS485 Communications Options Board (Type 481)	6-9
6.7	DC Output/RS485 Communications Options Board (Type 489)	6-10
6.8	Options Board 496	6-11
6.9	Options Board 497	6-13
6.10	Changing the Mains (Line) Supply Voltage	6-13
6.11	Assembling the Controller	6-13
6.11.1	Fitting the Options Board to the CPU Board (if required)	6-13
6.11.2	Fitting the Boards to the Front Panel Assembly	6-13
6.11.3	Fitting the Controller into the Housing	6-13

Appendices

Appendix A	Specification for 3700/3800 Controllers	A-1
Appendix B	Product Codes	B-1

Tables

Table	Title	Page
2-1	Thermocouple Cable Colour Codes	2-6
2-2	Protection Network Component Values	2-12
4-1	Parameter Ranges & Default Values	4-2
5-1	RS485 Channel Selection	5-3
5-2	Parameter Identifiers	5-6
5-3	{data} Field Format/Decimal Point Posn.	5-8
6-1	Thermocouple Input Link Jumpers	6-4
6-2	Break Protection - Link Jumper Settings	6-4
6-3	RTD Input Link Jumpers	6-5
6-4	Linear Input Link Jumper Settings	6-6
6-5	Alarm Output Link Jumper Settings	6-7
6-6	Options Board 468 - Link Jumper Settings	6-8
6-7	OP 2/Alarm Output - Link Jumper Settings	6-9
6-8	Options Board 489 - DC Output Jumpers	6-10
6-9	Option Board LJ Settings for CPU Board O/P	6-11
6-10	Options Board 496 - Link Jumper Settings	6-12
6-11	Options Board 497 - DC Output Link Jumpers	6-14
6-12	Option Board 497 - LJs for CPU Board O/P	6-14
6-13	Options Board 497 - Option Selection	6-14

Illustrations

Figure	Title	Page
2-1	Panel Cut-out Dimensions	2-1
2-2	Panel-mounting a Controller	2-1
2-3	Chassis Mounting Bracket	2-2
2-4	Location of Locking Screw	2-3
2-5	Rear Terminal Connections (Standard)	2-4
2-6	Connections (RSP and/or Recorder O/P)	2-4
2-7	Mains (Line) Supply Connections	2-5
2-8	Thermocouple Input Connections	2-5
2-9	Three-wire RTD Input Connections	2-6
2-10	DC Linear Input Connections	2-6
2-11	Relay Output 1 Connections	2-7
2-12	SSR Drive Output 1 Connections	2-7
2-13	DC Output 1 Connections	2-7
2-14	Relay Output 2 Connections	2-8
2-15	Output 2 SSR Drive Connections	2-8
2-16	DC Output 2 Connections	2-8
2-17	VMD (Open Loop) Connections	2-9

Illustrations (Continued)

Figure	Title	Page
2-18	VMD (Open Loop) - with Interlock	2-9
2-19	Alarm Output Connections	2-10
2-20	Remote Set Point Selection Connections	2-10
2-21	Remote Set Point Input Connections	2-10
2-22	Recorder Output Connections	2-11
2-23	RS485 Connections	2-11
2-24	External Switch/Inductive Load in Series	2-12
3-1	3700/3800 Controllers - Front Panels	3-1
4-1	Overlap/Deadband - OP 1 and OP2 Fitted	4-6
4-2	Setting-up Procedure	4-9
4-3	Tuning - OP 1 & OP 2 Fitted	4-11
4-4	Operation of Alarms	4-14
5-1	Option Board Type 481 - RS485 Switches	5-2
5-2	Option Board Type 489 - RS485 Switches	5-2
6-1	Detaching the PCBs from the Front Panel	6-3
6-2	Separating the Two PCBs	6-3
6-3	CPU Board Link Jumpers	6-5
6-4	Options Board 450 - Link Jumpers	6-7
6-5	Options Board 468 - Link Jumpers	6-8
6-6	Options Board 481 - Link Jumpers	6-9
6-7	Options Board 489 - Link Jumpers	6-10
6-8	Options Board 496 - Link Jumpers	6-12
6-9	Options Board 497 - Link Jumpers	6-15

SECTION 1

INTRODUCTION

The WEST 3700 and 3800 are compact "proportional plus integral plus derivative" (PID) controllers; the 3800 has an additional self-tuning facility. The facilities on both controllers include a wide range of inputs, proportional cooling output and auto/manual operation. The options available include the capability to operate as a slave via an RS485-compatible serial communications link. The front panel is equipped with red light-emitting-diode (LED) displays.

The controller housing conforms to 1/8 DIN measurements and controllers may be mounted conveniently side-by-side in multiple installations. Power consumption is only 3 watts approximately; therefore minimum ventilation is required.

1.1 OPERATOR CONTROLS AND INDICATORS

The controllers operate in either of two modes: **User Mode** or **Set-Up Mode**. In User Mode, the operator may adjust the set point value and monitor the controller outputs. In Set-Up Mode, all control parameters can be reviewed and adjusted.

The controller front panel has a number of operator controls and indicators to serve the following functions:

Upper display: Normally displays the value of the process variable. In Set-Up Mode, set point and other control parameter values are displayed after selection by means of the front panel pushbuttons.

Lower display: Normally displays the set point value. In Set-Up Mode, it displays a legend which identifies the control parameter being viewed/adjusted.

LED Indicators: The 3700 and 3800 front panels are equipped with seven LEDs which indicate the various output states and Controller functions.

Controls: Four pushbuttons are provided for parameter entry and for selection of Controller functions.

Full details of the use of these controls and indicators can be found in Section 3.

1.2 OPTIONS AND VARIANTS

There is a wide range of options and variants available for the 3700 and 3800 Controllers. The variants and options fitted to each controller are indicated by the product codes shown on the product code label affixed to the side of the controller. Space is available on the label for alteration of these codes should any of the variants or options be changed subsequently. Full details of the options and variants available and guidance on interpretation of the product code label are given in Appendix B.

SECTION 2 INSTALLATION

2.1 UNPACKING PROCEDURE

1. Remove the controller from its packaging. The controller is supplied with a mounting clamp and two screws. If a Remote Front Panel option (X74, X75 or X79) has been ordered, the package should also contain the remote front panel and the connecting cable with terminating plugs.

NOTE

Retain the packing for future use, should it be necessary to transport the controller to another site or to return it to the supplier for repair.

2. Examine the delivered items to check for damage or deficiency. If any is found, notify the carrier immediately. Check that the product code shown on the product code label (affixed to the side of the controller) corresponds to the controller ordered.

2.2 PANEL-MOUNTING A STANDARD CONTROLLER

2.2.1 Pre-Requisites

The panel on which the controller is to be mounted must be rigid and may be up to 6.00 mm (0.25 inches) thick. The cut-out required is as shown in Figure 2-1.

Several controllers may be mounted side-by-side in a continuous cut-out of width:

$$(48n - 4)\text{mm or } (1.89n - 0.16)\text{ inches}$$

where n is the number of controllers to be installed.

The controller is 150mm (5.90 in) deep, measured from the rear face of the front panel. The front panel is 96.00 mm (3.80 in) high and 48.00mm (1.89 in) wide; when panel-mounted, it projects out 6.00mm (0.25 in) from the panel.

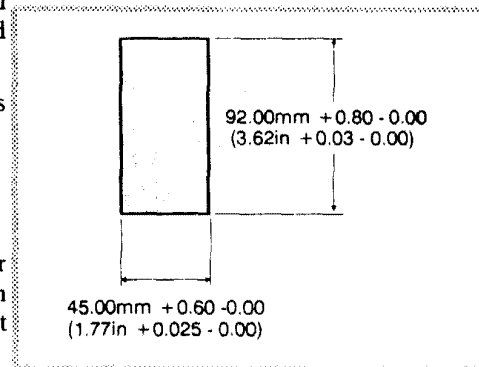

Figure 2-1 Panel Cut-out Dimensions

2.2.2 Panel-Mounting Procedure

1. Insert the rear of the controller housing through the cut-out (from the front of the panel) and hold the controller lightly in position against the panel.
2. Slide the mounting clamp into place on the controller (see Figure 2-2) and push it forwards until it touches the rear face of panel. Teeth on the arms which project to the rear of the clamp will engage with the ratchets moulded into the top and bottom surfaces of the controller housing.
3. Gently tighten the screws in the clamp till the front panel is fitted snugly in the cut-out in the mounting panel.

CAUTION

Do not over-tighten the screws; this will distort the mounting clamp.

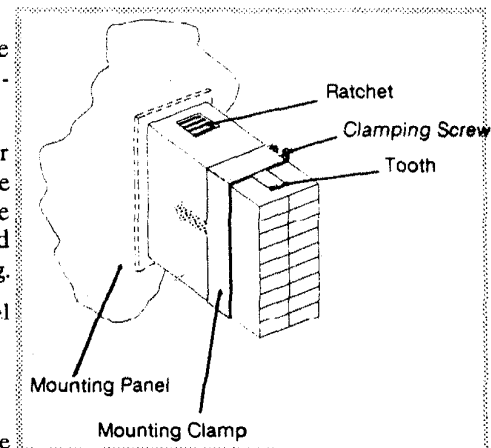

Figure 2-2 Panel-mounting a Controller

2.3 PANEL-MOUNTING A CONTROLLER WITH A REMOTE FRONT PANEL

2.3.1 Pre-Requisites

2.3.1.1 REMOTE FRONT PANEL

The cut-out required for the remote front panel is the same as that for the standard controller (see Figure 2-1). The remote front panel is 28.00 mm (1.10 in) deep, measured from the rear face of the front panel. It is 96.00mm (3.8 in) high, 48.00mm (1.89 in) wide and, when panel-mounted, it projects 6.00mm (0.25 in) out from the panel.

2.3.1.2 CONTROLLER

The cut-out required for the controller is the same as that for the standard controller (see Figure 2-1).

2.3.2 Panel-Mounting Procedure

2.3.2.1 REMOTE FRONT PANEL

1. Remove the mounting clamp from the front panel by undoing the screw which holds it in place.
2. Insert the remote front panel into the cut-out in the mounting panel.
3. Holding the front panel in position, re-attach the mounting clamp, securing the front panel in position.

2.3.2.2 CONTROLLER

The controller may be mounted in the same manner as the standard controller (see Subsection 2.2.2 and Figure 2-2) or it may be secured with a chassis mounting bracket as described in the following procedure (see also Figure 2-3):

1. Attach the chassis mounting bracket to the mounting panel or chassis by means of suitable screws or bolts (maximum thread diameter – 4mm).
2. Insert the controller through the aperture in the bracket and attach it to the bracket by means of the mounting clamp, in the same manner as for mounting a standard controller to a mounting panel.

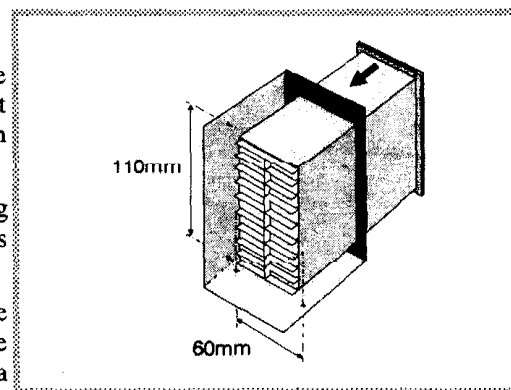

Figure 2-3 Chassis Mounting Bracket

2.3.3 Connecting the Controller to the Remote Front Panel

The controller with a remote front panel is supplied with an inter-connecting cable. This is installed by inserting the two ends of the cable into the IDC sockets on the remote front panel and the front of the controller (ensure that the plastic key on each of the cable connectors engages with the keyway in the corresponding connector). The connectors are secured in place by squeezing together the plastic retainer clips.

CAUTION

Do not run the inter-connecting cable in close proximity to power-carrying cables.

2.4 REMOVAL OF THE CONTROLLER FROM ITS HOUSING

The controller can be removed from its housing (for servicing purposes or to replace sub-assemblies), leaving the housing and back-wiring attached to the mounting panel.

CAUTION

The mains (line) supply must be disconnected from the controller before any attempt is made to remove the controller from its housing.

The controller contains a lithium battery and devices which are sensitive to electrostatic discharge. During handling of the controller, precautions should be taken to minimise the risk of electrostatic discharge or short-circuiting of the battery i.e.:

- * Do not place the unboxed controller on a conducting surface.
- * Touch only the edges of the PCBs in the controller. Ensure that fingers do not come into contact with any of the components or tracks on the PCB
- * Before handling the unboxed controller, touch a nearby ground connection e.g. a metal bench frame or rack.
- * If possible, wear an earth wrist strap whilst handling the unboxed controller.

IF BATTERY REPLACEMENT IS REQUIRED, THIS SHOULD BE PERFORMED BY A TRAINED TECHNICIAN.

To remove the controller from its housing, proceed as follows:

1. With a flat-bladed screwdriver of appropriate size (1/4-inch), rotate the locking screw (see Figure 2-4) anticlockwise until the locking screw thread is completely dis-engaged. This will partially move the controller out of the housing and dis-engage the connections at the rear of the controller (inside the housing).
2. Carefully pull the controller forwards clear of the housing.

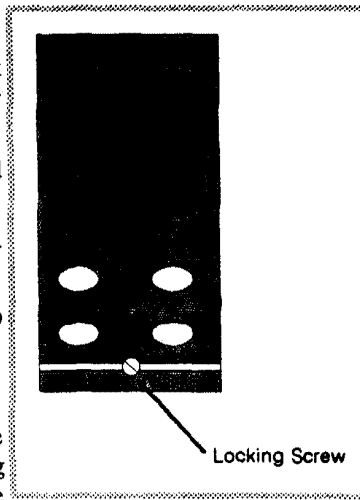

Figure 2-4 Location of Locking Screw

2.5 REPLACEMENT OF THE CONTROLLER IN ITS HOUSING

1. Carefully slide the controller into its housing, ensuring that the controller PCB(s) locate against the outside of the card guides moulded in the top and bottom of the housing.
2. Push the controller firmly into place such that sound connection is made between the controller PCBs' edge connectors and the rear connections inside the housing.
3. Engage the thread of the locking screw and tighten the locking screw until the controller is securely in position in the housing.

2.6 CONNECTIONS AND WIRING

The following connections for outputs and inputs are provided at the rear of the controller housing (with some controller configurations, some of the connections may not be present):

- * Mains (Line) input
- * Thermocouple, resistance temperature detector (RTD) or DC linear input
- * Output 1 (HEAT) - Relay, solid state relay (SSR) or DC output.
- * Output 2 (COOL) - Relay, SSR or DC output.
- * Valve motor drive (VMD) output - open loop version (Model 3800 only)
- * Alarm output
- * RS485-compatible serial communications input/output
- * Remote set point input
- * Recorder output

The connections to the rear terminals are shown in Figure 2-5 (for controllers not equipped with Remote Set Point input) and Figure 2-6 (for controllers equipped with Remote Set Point input).

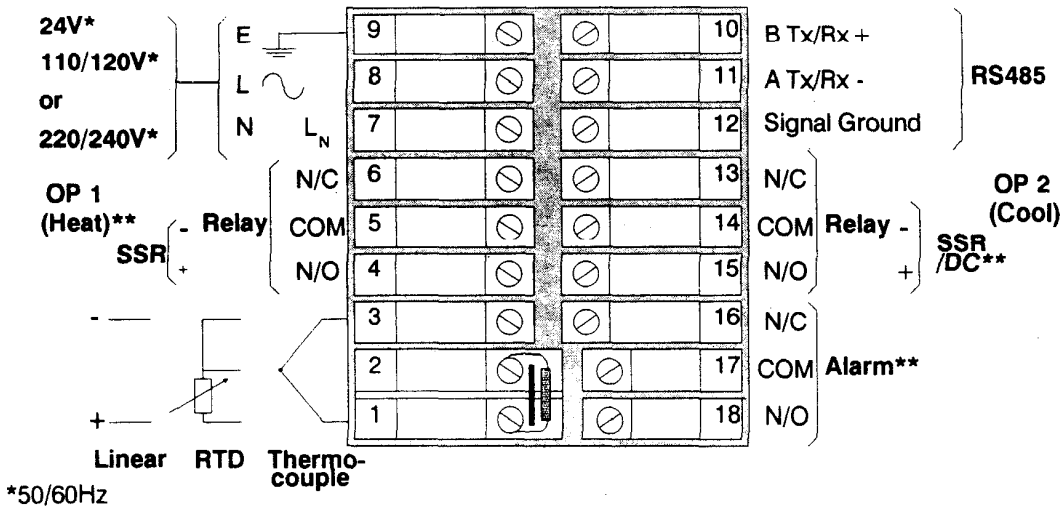

Figure 2-5 Rear Terminal Connections (Standard)

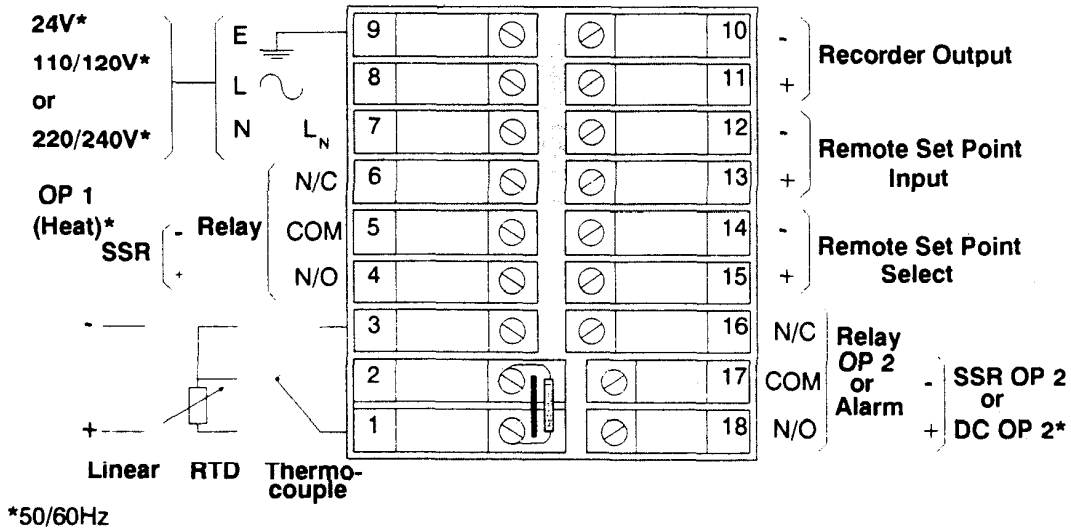
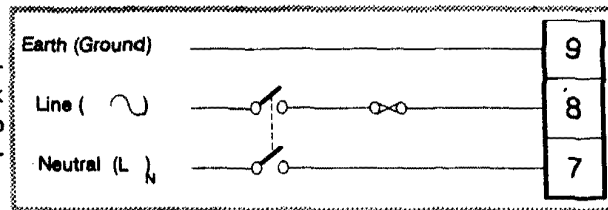

Figure 2-6 Connections (RSP and/or Recorder O/P)

2.6.1 Mains (Line) Input

The controller is supplied to operate on 24V, 100 - 132V or 193 - 264V AC supplies (50/60Hz). Check that the installation mains voltage corresponds to that indicated on the product code label before connecting power to the controller.

**Figure 2-7 Mains (Line) Supply Connections****CAUTION**

This equipment is designed for installation in an enclosure which provides adequate protection against electric shock. Local requirements regarding electrical installation should be rigidly observed. Ground terminals must be connected separately and must not be made common with the neutral connection. Consideration should be given to the prevention of unauthorised personnel from gaining access to the power terminations. The Ground terminal 9 should be connected to a protective ground conductor before any other connections are made and should remain connected at all times. Power should be connected via a two-pole isolating switch and a 1A (193 - 264V supply), 2A (100 - 132V supply) or 5A (24V supply) fuse, as shown in Figure 2-7.

2.6.2 Thermocouple Input

Thermocouple input connections are shown in Figure 2-8. The correct type of thermocouple extension leadwire or compensating cable must be used for the entire distance between the controller and the thermocouple, ensuring that the correct polarity is observed throughout. Joints in the cable should be avoided, if possible. All controllers supplied with a thermocouple input have a cold junction compensation unit connected across terminals 1 and 2. This unit should never be removed.

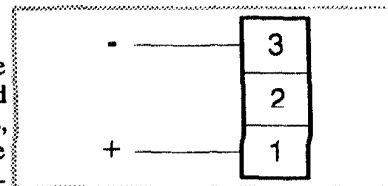
**Figure 2-8 Thermocouple Input Connections****NOTE**

Do not run thermocouple cables adjacent to power-carrying conductors. If the wiring is run in a conduit, use a separate conduit for the thermocouple wiring. If the thermocouple is grounded, this must be done at one point only. If the thermocouple extension lead is shielded, the shield must be grounded at one point only.

The colour codes used on the thermocouple extension leads are shown in Table 2-1.

Table 2-1 Thermocouple Cable Colour Codes

Thermocouple Type	Cable Material	British (BS)	American (ASTM)	German (DIN)	French (NFE)
T	Copper Constantan	+ white - Blue * Blue	+ Blue - Red * Blue	+ Red - Brown * Brown	+ Yellow - Blue * Blue
J	Iron/Constantan	+ Yellow - Blue * Black	+ White - Red * Black	+ Red - Blue * Blue	+ Yellow - Black * Black
K	Nickel Chromium Nickel Aluminium	+ Brown - Blue * Red	+ Yellow - Red * Yellow	+ Red - Green * Green	+ Yellow - Purple * Yellow
R	13% Copper	+ White	+ Black	+ Red	+ Yellow
S	10% Copper Nickel	- Blue * Green	- Red * Green	- White * White	- Green * Green
B	Platinum/Rhodium		+ Grey - Red * Grey		

* Colour of overall sheath.

2.6.3 Three-wire Resistance Temperature Detector (RTD) Input

RTD connections are shown in Figure 2-9, with the compensating lead connected to Terminal 3. For two-wire RTD inputs, Terminals 2 and 3 should be linked. The extension leads should be of copper and the resistance of the wires connecting the resistance element should not exceed 5 ohms per lead (the leads should be of equal length).

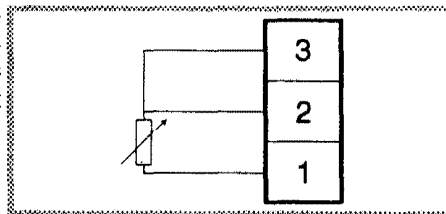

Figure 2-9 Three-wire RTD Input Connections

2.6.4 DC Linear Inputs

Any one of a range of linear inputs can be accommodated on the controller (see Appendix B). Connections for linear inputs are as shown in Figure 2-10.

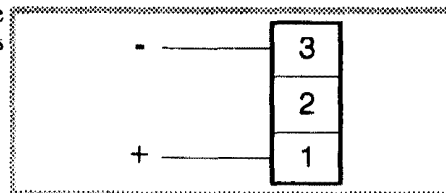

Figure 2-10 DC Linear Input Connections

2.6.5 Output 1 (Heat)

2.6.5.1 RELAY OUTPUT 1 (PRODUCT CODE --H10--)

The Output 1 relay has contacts connected to the rear terminals on the controller. The contacts are rated at 5A 240V AC with a resistive load. When the relay is energised, the front panel OP 1 indicator is illuminated. The connections for the Output 1 relay are as shown in Figure 2-11.

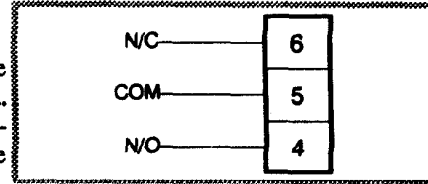

Figure 2-11 Relay Output 1 Connections

Refer also to Subsection 2.7.

2.6.5.2 SSR DRIVE OUTPUT 1 (PRODUCT CODE --H50--)

Controllers fitted with the SSR Output 1 produce a time-proportioned non-isolated DC signal (0V - 12V nominal, output impedance 250 ohms). This is suitable for driving the WEST 2200 Series Thyristor Units or other solid state relays with an isolated input. When Output 1 is ON, the front panel OP 1 indicator will be illuminated. The connections are as shown in Figure 2-12.

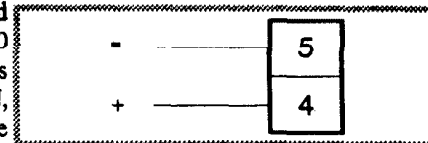

Figure 2-12 SSR Drive Output 1 Connections

2.6.5.3 DC OUTPUT 1 (PRODUCT CODES H21, H24, H61 & H64)

Refer to Appendix B for details of these outputs.

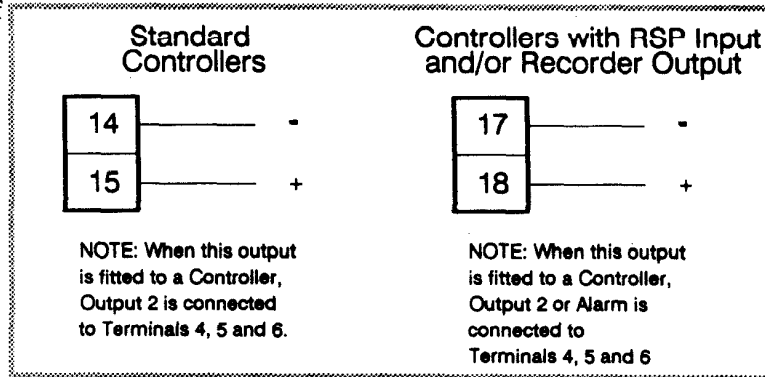

Figure 2-13 DC Output 1 Connections

2.6.6 Output 2 (Cool)

NOTE

If Output 1 is reverse-acting, Output 2 is direct-acting and vice versa.

2.6.6.1 OUTPUT 2 RELAY (PRODUCT CODE --C10--)

The Output 2 relay has single-pole double-throw contacts connected to the rear terminals as shown in Figure 2-14. The contacts are rated at 2A 240V AC with a resistive load. When the relay is energised, the front panel OP 2 indicator is set ON. Refer also to Subsection 2.7.

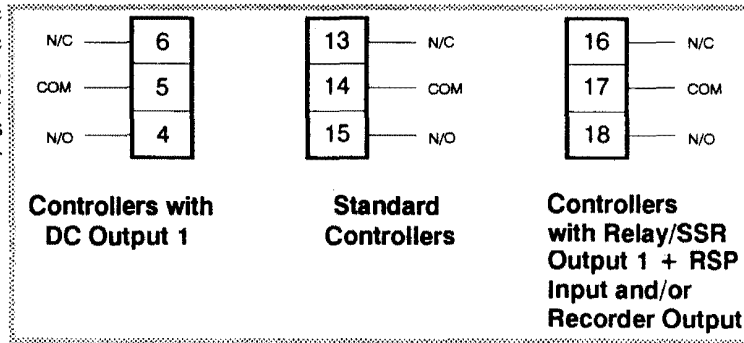

Figure 2-14 Relay Output 2 Connections

2.6.6.2 OUTPUT 2 SSR DRIVE (PRODUCT CODE --C50--)

Controllers with this output produce a time-proportioned non-isolated DC signal (0V/12V nominal, output impedance 250 ohms).

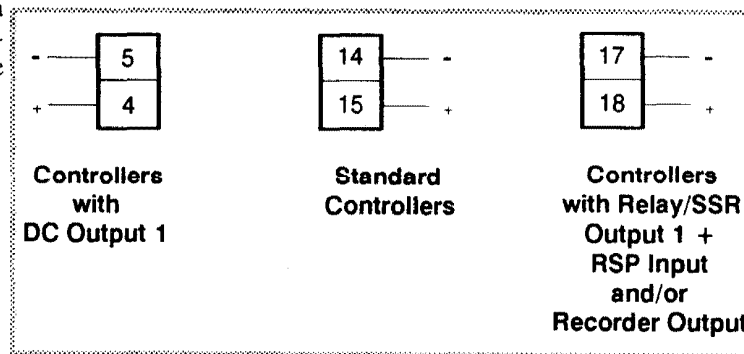

Figure 2-15 Output 2 SSR Drive Connections

2.6.6.3 DC OUTPUT 2 (PRODUCT CODES C21, C24, C61 OR C64)

Refer to Appendix B for details of these outputs.

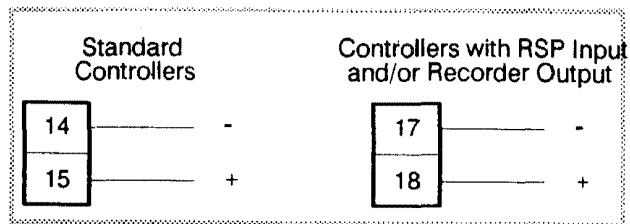

Figure 2-16 DC Output 2 Connections

2.6.7 VMD Open Loop Output - Model 3800 Controllers Only

NOTE

When this output is fitted, the Pre-Tune/Self-Tune facilities are not available. The following additional options are available:

RS485 Serial Communications only

Alarm only

Remote Set Point Input and/or Recorder Output

This output cannot be re-configured to any other type of output. The connections for a VMD Open Loop Output are shown in Figure 2-17. The Controller is designed to switch on either the Output 1 relay or the Output 2 relay (i.e. to open or close the valve). However, under fault conditions, both relays can be switched on simultaneously. An interlock can be provided for safety purposes (see Figure 2-18). This connects the supply to the motor via the "normally-closed" contacts on the relays. Refer also to Subsection 2.7.

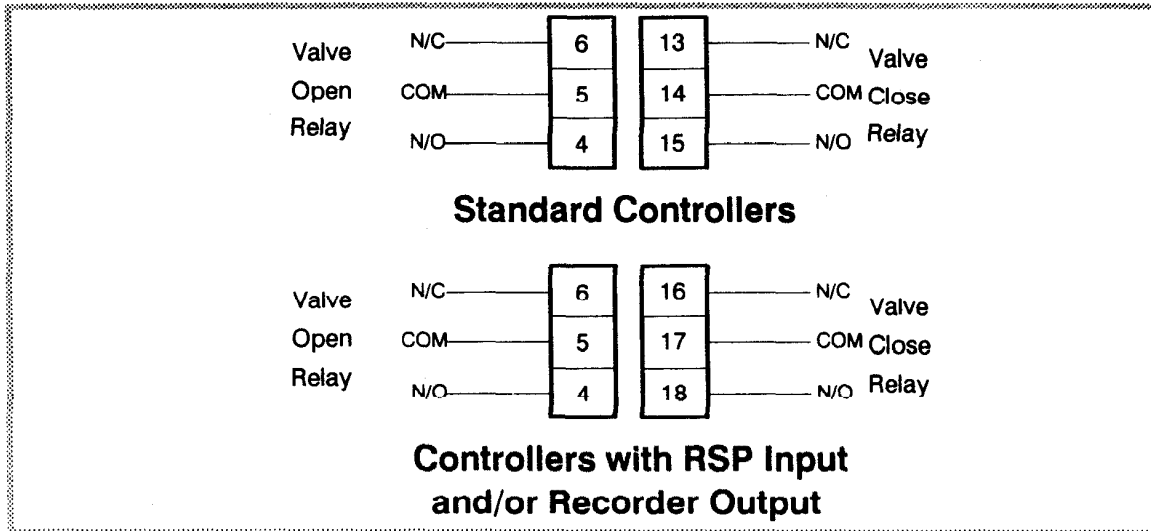

Figure 2-17 VMD (Open Loop) Connections

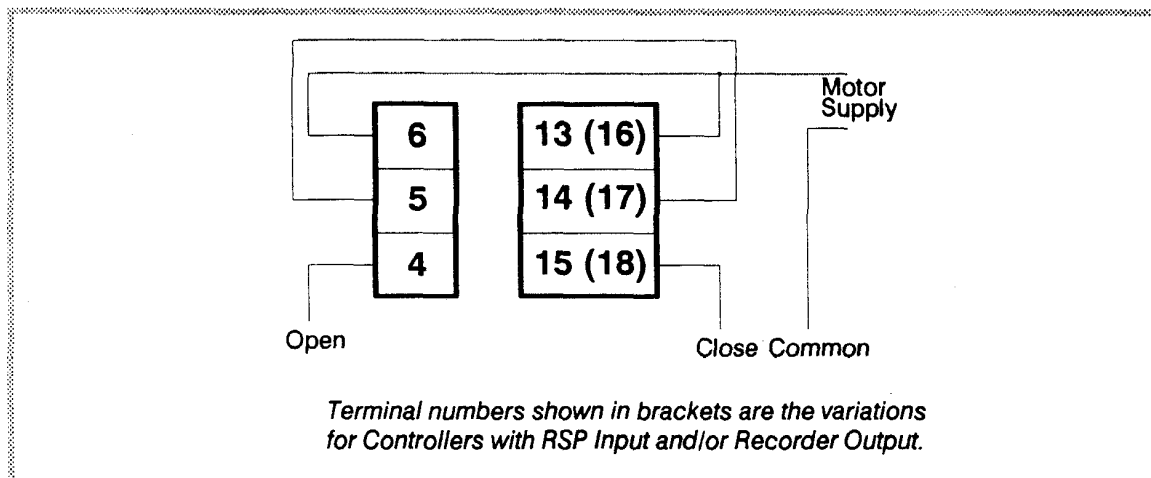

Figure 2-18 VMD (Open Loop) - with Interlock

2.6.8 Alarm Output - Optional (Product Codes --C--46 to --C--51)

The relay connections for an alarm output are shown in Figure 2-19. Details of the operations of the various types of alarms may be found in Subsection 4.6.

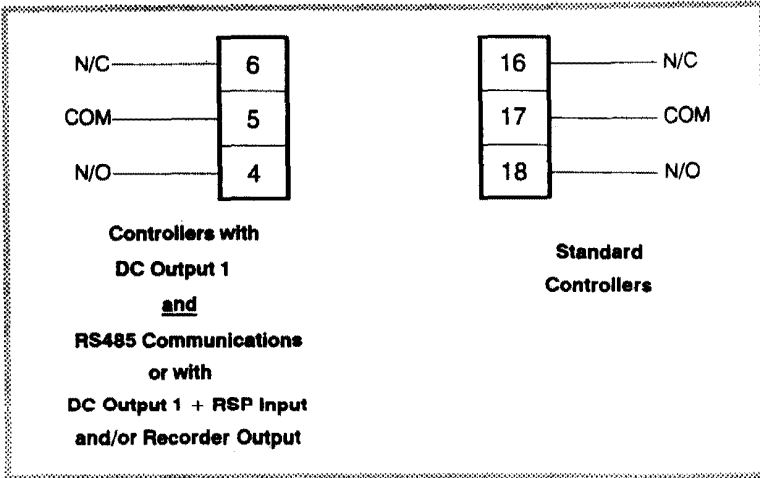

Figure 2-19 Alarm Output Connections

2.6.9 Remote Set Point Input - Product Codes X04(40), X05(40), X37(40) and X38(40)

2.6.9.1 REMOTE SET POINT INPUT SELECTION

The connections for the Remote Set Point Input Selection are shown in Figure 2-20. The Remote Set Point input is selected by applying 5V DC to Terminals 14 and 15.

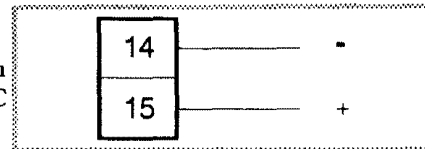

Figure 2-20 Remote Set Point Selection Connections

NOTE

Do not run leads adjacent to any power-carrying conductors. If the wiring is run in a conduit, use a separate conduit for the input wiring. If the input wiring is earthed, this should be done at one point only.

2.6.9.2 REMOTE SET POINT INPUT

The connections for the Remote Set Point input are shown in Figure 2-21. This input is used to receive the voltage or current level which defines the Remote Set Point value. The device connected to this input may be either a current source or a voltage source. Refer to Appendix B for details of the range of Remote Set Point inputs available.

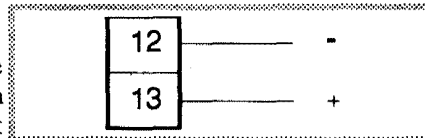

Figure 2-21 Remote Set Point Input Connections

2.6.10 Recorder Output (Product Codes X12, X18, X19 and X20)**NOTE**

This Option is not available with RS485 Communications (Product Code X06). Also, when this option is fitted, it is possible to have either Output 2 or Alarm output *but not both*.

The connections for the Recorder Output are shown in Figure 2-22.

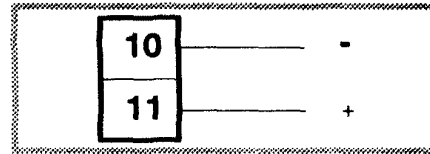

Figure 2-22 Recorder Output Connections

2.6.11 RS485-Compatible Serial Communications Link

Controllers which are fitted with the RS485 Communications Option use terminals 10, 11 and 12 as shown in Figure 2-23.

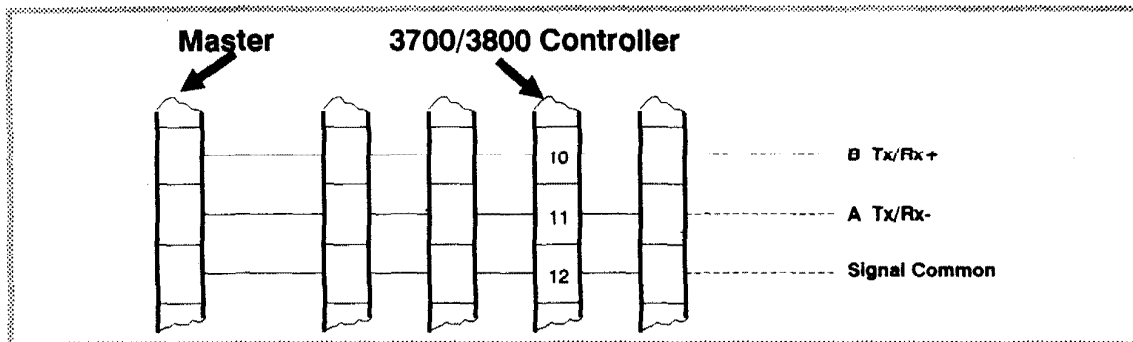

Figure 2-23 RS485 Connections

2.7 INDUCTIVE LOADS; EXTERNAL CONTACTORS AND MAINS-OPERATED RELAYS**WARNING**

Operating the Controller with inductive loads and without the appropriate protection components may give rise to a hazard owing to high-voltage transients which may occur during the switching cycles. *Removal of the Controller's internal snubber components could give rise to a serious hazard. Gulston Limited and Mark IV Industries do not accept responsibility for any damage which may occur as a consequence of the unauthorised removal of these components.*

2.7.1 General Notes

The standard relay contacts fitted in the Controller are suitable for AC supply voltages in the range 24V to 240V. The Output 1 relay is rated at up to 5A with a resistive load and up to 1A with an inductive load. The Alarm and Output 2 relays are rated at up to 2A with a resistive load and up to 1A with an inductive load. The Model 3700 and 3800 Controllers contain voltage-dependent resistors (VDRs) across all relay contacts; these protect the internal circuits for all loads up to the maximum rating. No external protection components are necessary unless an external switch or contact is fitted in series with the Controller relay contacts (see Subsection 2.7.2).

2.7.2 An External Switch in Series with an External Inductive Load

Damage may be caused to the Controller if the contacts of a switch, relay or contactor are connected externally in series with the Controller relay contacts, as shown in Figure 2-24.

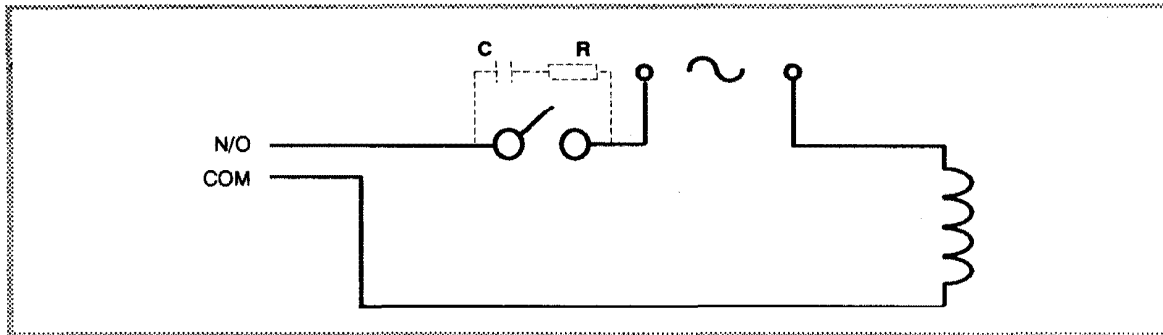

Figure 2-24 External Switch/Inductive Load in Series

Under these conditions, the external contacts may operate whilst the Controller relay contacts are closed (i.e. when the internal protection components are short-circuited and, therefore, ineffective).

In applications in which it is necessary to fit the contacts of an external switch, relay or contactor in series with the Controller relay, a suitable VDR or a snubber network must be fitted, either across the inductive load or across the unprotected contacts (the components shown in dotted outline in Figure 2-24). The values shown in Table 2-2 may be used for these components.

Table 2-2 Protection Network Component Values

Load Current	Value of C(μ F)	West Part No.	Value of R(Ω)	West Part No.
70mA	0.047	22206	22	23220-304
150mA	0.100	22207	47	23470-304
500mA	0.220	22208	47	23470-304
1A	0.470	22209	47	23470-304

NOTE

All capacitors should conform to VDE (Class X) and should be suitable for operation at 260V AC. All resistors (wirewound or Allen Bradley Type HB) should have a minimum rating of 2 watts.

SECTION 3 OPERATING INSTRUCTIONS

3.1 INTRODUCTION

These instructions are based on the assumption that the controller has been set up and is in User Mode. In User Mode, both the process variable (shown in the upper display) and the set point (shown in the lower display) may be viewed. The set point value may be adjusted; the process may also be brought under manual control (unless Auto/Manual selection has been disabled).

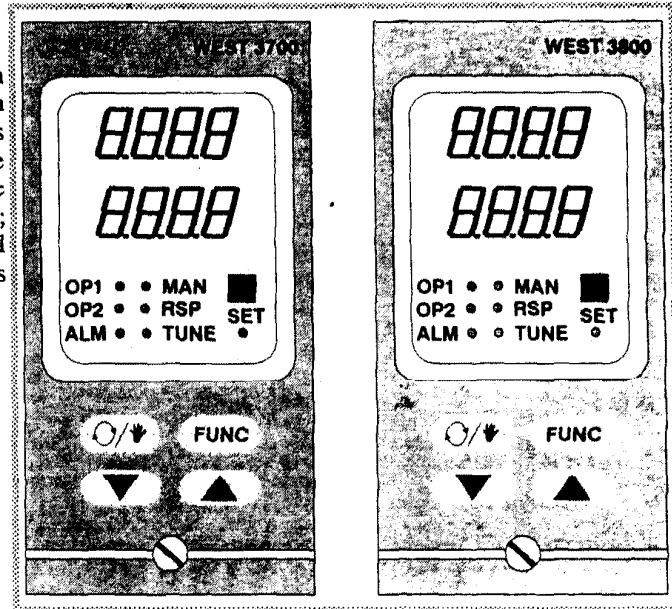

Figure 3-1 3700/3800 Controllers - Front Panels

3.2 DISPLAYS (USER MODE)

Upper display: This displays the value of the process variable.
 Lower display: This displays the set point value. It is also used to display parameter legends:

SP - set point adjustment

Pxxx - for Manual Control (xxx indicates the power output). This parameter is skipped if Auto/Manual selection is disabled.

NOTE

The units for the process variable (e.g. °F or °C) are displayed in a window on the lower right of the display group.

3.3 FRONT PANEL INDICATORS

OP 1 This indicates the state of the Output 1 relay or SSR drive:

ON = relay energised or SSR drive ON

OFF = relay de-energised or SSR drive OFF

or (on Model 3800 Controllers fitted with the VMD Output Option) this indicator being ON indicates that the valve is opening.

- OP 2** Optional - This indicates the state of the Output 2 relay or SSR drive:
ON = relay energised or SSR drive ON
OFF = relay de-energised or SSR drive OFF
or (on Model 3800 Controllers fitted with the VMD Output Option) this indicator being ON indicates that the valve is closing.
- ALARM** (Optional) This indicator flashes to indicate an Alarm condition (see Subsection 4.6 for details of alarm operation).
- RSP** Optional - This indicator is ON when the Remote Set Point input is selected.
- MAN** Not applicable if Auto/Manual selection is disabled - This flashes when Manual Control has been selected. In this mode, the power output value (in the range 0% - 100% for controllers with Output 1 only, or -100% - +100% for controllers with Output 1 and Output 2) is shown on the lower display.
- SET** This indicates that Set-Up Mode is selected (see Section 4 for details of Set-Up Mode).
- TUNE** Model 3800 Controllers only. Self-Tune and Pre-Tune indicator - see Subsection 4.5.

3.4 FRONT PANEL CONTROLS



Raise pushbutton. Used to increase the value of the selected parameter.



Lower pushbutton. Used to decrease the value of the selected parameter.

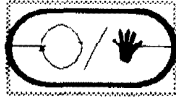

Auto/Manual Control Pushbutton. Used to select/de-select Manual Control of power output.



Selects parameters in sequence for display.

3.5 SELF-TEST PROCEDURE

When the controller is powered-up, a self-test procedure is automatically started, during which all LED segments in the two front panel displays appear and all LED indicators for the facilities fitted are ON. When the self-test procedure is complete, the controller reverts to normal operation.

3.6 NORMAL DISPLAY

On completion of the self-test procedure, the controller is in normal display mode. The upper display indicates the current value of the process variable and the lower display indicates the current value of the set point.

3.7 SET POINT ADJUSTMENT

3.7.1 Set Point or (on Controllers with RSP Input) Local Set Point

To adjust the value of the set point, proceed as follows:

1. Depress the FUNC pushbutton. The lower display will show the legend:



on standard Controllers, or



on Controllers fitted with RSP input. The upper display will show the current value of the set point.

2. Adjust the set point value using the Raise and Lower pushbuttons as applicable.

NOTE

When either the Raise or Lower pushbutton is depressed momentarily, the set point value will be incremented or decremented (as appropriate) by one unit in the least significant digit. If the pushbutton is held depressed for longer than one second, the least significant digit of the set point value is incremented or decremented (as appropriate) at the rate of 25 per second. If the pushbutton is held depressed for longer than 10 seconds, the second least significant digit of the set point value will change at the rate of 25 per second.

3. When the set point has been adjusted to the required value, return to the normal display mode by depressing the FUNC pushbutton.

3.7.2 Remote Set Point

When the Remote Set Point input is selected, the lower display will show the legend:



and the upper display will show the value of the Remote Set Point, as defined by the value of the voltage/current received at Terminals 12 and 13. This is a Read Only display and cannot be adjusted by the Controller.

3.8 RAMPING SET POINT



This facility, when enabled, is activated at start-up (ramping from the Process Variable) and thereafter whenever the Set Point value is changed. The ramp rate is defined by the value of the Ramping Set Point Rate (rP) parameter (see Section 4).

NOTES

1. If rP > 9999, the Ramping Set Point facility is disabled; at start-up, the internal set point will go immediately to its final value.
2. The Auto Pre-Tune facility is disabled whilst the Ramping Set Point facility is enabled. If both modes are selected on power-up, the Controller will enter Ramping Set Point mode and the Auto

Pre-Tune facility will be inhibited. If the Self-Tune facility has been selected, it will commence only after the set point has finished ramping.

3.9 MANUAL CONTROL

NOTE

Manual Control is not applicable if the Auto/Manual selection facility is disabled.

CAUTION

Extreme caution should be exercised in the use of the Manual Control facility to avoid the possibility of damage to either the process or the process equipment.

3.9.1 Entering and Leaving Manual Control

To select Manual Control, press the Auto/Manual pushbutton:



During Manual Control, the MAN front panel indicator will flash continuously. The lower display will show the current value of power output in the form:

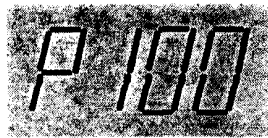

and the upper display will show the current value of the process variable. The value of output power may be adjusted using the Raise and Lower pushbuttons as required. The output power value can be varied in the range 0% - 100% for controllers fitted with Output 1 only, or in the range -100% - +100% for controllers fitted with both Output 1 and Output 2.

NOTES

1. On Model 3800 Controllers with the VMD Output Option, in Manual Control Mode, the Raise and Lower pushbuttons are used as follows:

(a) The Raise pushbutton is used to energise the Output 1 relay and will cause the OP 1 indicator to go ON.

(b) Depression of the Lower pushbutton will energise the Output 2 relay and will cause the OP 2 indicator to go ON.

Output 2 (the Lower pushbutton) will be used in the reverse sense to Output 1 (the Raise pushbutton) i.e. either one is used to open the valve, the other is used to close the valve.

2. If the Controller is powered-down whilst in Manual Control mode, it will remain in Manual Control mode when power is restored to the Controller. The power output level will be as it was at the instant of power-down.

To exit from Manual Control, depress the Auto/Manual pushbutton, whereupon the controller will return to Automatic Control.

3.9.2 Manual Control Displays

Whilst the process is under Manual Control, the displays described above will be shown. If the FUNC pushbutton is depressed, the upper display will show the current set point value which may be adjusted as described in Subsection 3.7.

Depressing the FUNC pushbutton a second time causes the display to revert to showing the power output value.

3.10 DEFAULT PARAMETER INDICATION

If the controller is operating with default values, the upper display will show a decimal point after each digit of the displayed value.

See Section 4 for details of setting up control parameter values.

3.11 REMOTE CONTROL VIA THE RS485-COMPATIBLE LINK

If the controller is fitted with the RS485-compatible serial communications facility (Option X06) and this has been enabled (see Section 5), parameters may be changed via this communications link.

SECTION 4

SETTING-UP PROCEDURES

4.1 TO ENTER SET-UP MODE

With the controller in User Mode, the upper display showing the current value of the process variable and the lower display showing the current value of the set point, proceed as follows:

1. Depress and hold down the Raise and Lower pushbuttons simultaneously until the front panel SET indicator starts to flash.
2. Within 3 seconds of the SET indicator starting to flash, depress and hold down the FUNC pushbutton until the SET indicator is continuously ON.

The controller is now in Set-Up Mode.

NOTE

When the controller is in Set-Up Mode, if one minute elapses during which no pushbutton is operated, the controller will return automatically to User Mode.

4.2 TO DISPLAY AND, IF REQUIRED, ADJUST A PARAMETER

When Set-Up Mode is entered, the upper display will show the current value of the process variable and the lower display will show the current value of the set point. Subsequently, each depression of the FUNC pushbutton will step the controller through the sequence of displays shown in Table 4-1. Each display will show the value of the selected parameter (in the upper display) and the legend which identifies that parameter (in the lower display). While each parameter is displayed, the operator may adjust the value of that parameter, within the permitted range, by use of the Raise and Lower pushbuttons. The upper and lower displays will flash if the operator attempts to:

- (a) adjust a parameter to a value outside the range of adjustment,
- (b) adjust a parameter to a value beyond the limit set by another parameter (e.g. SP Limit),
- (c) adjust a "read only" parameter (e.g. process variable).

In such instances, the attempted adjustment will not be implemented.

Table 4-1 Parameter Ranges & Default Values

















Parameter	Legend	Range	Default Value
Set Point ⁹	 	Between SP High Limit and SP Low Limit	Range Minimum
Remote Set Point ¹⁰		Between SP High Limit and SP Low Limit	
Ramping Set Point		Span of Controller	
Output Power		-100% to +100% (Adjustable in Manual Control). Not applicable for VMD Output.	Read Only - adjustable in Manual Control. Not available if VMD Option fitted
Proportional Band		0% to 1000% of span (1% to 1000% for VMD Output)	10%
Integral Time Constant ¹		10 secs. - 30 mins. and OFF (VMD Output: 10 secs. - 99 mins. 59 secs. - no OFF setting available)	5 mins. 00 secs.
Derivative Time Constant ¹		00 secs. - 10 mins.	30 secs. (3700) 1 min. 15 secs. (3800) 00 secs. (VMD Output)
Relative Gain ¹		0.02 - 1.00 and ON/OFF (> 1.00)	1.00
Overlap/Deadband ¹		-20% to +20% of Proportional Band	0%
On/Off Differential ²		0.1% to 10% of span of Controller	
OP 1 Only			
OP 2 Only			
OP 1 & OP2			
Set Point High Limit		Set Point to Range Maximum	Range Maximum
Set Point Low Limit		Range Minimum to Set Point	Range Minimum
RSP Scale Maximum ¹⁰		(RSP Scale Min. + 1) to 9999	Range Maximum

Table 4-1 (Cont.) Parameter Ranges & Default Values

Parameter	Legend	Range	Default Value
RSP Scale Minimum ¹⁰		-1999 to (RSP Scale Max. - 1)	Range Minimum
Recorder Output Scale Maximum		-1999 to 9999	Range Maximum
Recorder Output Scale Minimum		-1999 to 9999	Range Minimum
Output 1 Power Limit ¹		0% to 100% of full power	100%; not available if VMD Option is fitted
Output 1 Cycle Time ¹		0.5, 1, 2, 4, 8, 16, 32 or 64 seconds	32 seconds
Output 2 Cycle Time ¹		0.5, 1, 2, 4, 8, 16, 32, 64, 128, 256 or 512 seconds	32 seconds
Output 2 Value ³		± span from Set Point	0
Process Alarm Value ⁴		Range Minimum to Range Maximum	Range Maximum
Band Alarm Value ⁴		0 to span from Set Point	5 units
Deviation Alarm Value ⁴		± span from Set Point	5 units
Ramping Set Point Rate		+1 to +9999 and OFF (rP > +9999)	OFF
Motor Travel Time ⁸		5 seconds to 5 minutes in 1-second increments	1 minute
Motor Switching Hysteresis ⁸		0.04% to 5% of travel in 0.01% increments	1%
Scale Range Decimal Point ⁵		0, 1, 2 or 3	1
Scale Range Maximum ⁵		(rLo + 1) to 9999	1000
Scale Range Minimum ⁵		-1999 to (rhi - 1)	0000
Auto Pre-Tune Enable/Disable ⁷		0 (Disabled) or 1 (Enabled)	0
Manual Control Enable/Disable		0 (Disabled) or 1 (Enabled)	0

NOTES ON TABLE 4-1

1. These parameters are not operative or accessible if the Proportional Band (**Pb**) = 0%.
2. Switching differential with ON/OFF relay output.
3. Accessible only if Output 2 is fitted and is set to ON/OFF mode (Relative Gain (**rCG**) > 1.00).
4. These parameters are optional. Refer to Subsection 4.6 for details of alarm operation.
5. Only accessible if DC Linear Input is fitted.
6. 0% to 100% on Controllers with Output 1 only or with Output 2 set to ON/OFF mode (Relative Gain > 1.00).
7. Model 3800 Controllers only.
8. Model 3800 Controllers fitted with VMD Output only.
9. On Controllers not fitted with the Remote Set Point option, the set point legend is **SP**. On Controllers fitted with the Remote Set Point option, the legend for the display of the Local (i.e. internal) Set Point is **LSP**.
10. Applicable only to Controllers fitted with the Remote Set Point option.

4.3 CONTROL PARAMETERS**4.3.1 Set Point - SP/Local Set Point - LSP**

This parameter is the desired value of the process variable. It can be adjusted within the range defined by the Set Point High Limit (**SPHi**) and the Set Point Low Limit (**SPLo**). The default value is the Scale Range Minimum (**rLo**).

4.3.2 Remote Set Point - rSP

This parameter is the desired value of the process variable, as defined by the voltage or current at the Remote Set Point input (Terminals 12 and 13) of the Controller. It can be adjusted within the range defined by the Set Point High Limit (**SPHi**) and the Set Point Low Limit (**SPLo**).

4.3.3 Ramping Set Point - SPrP

When this legend appears in the lower display, the upper display shows the current value of a ramping set point (a Read Only display).

4.3.4 Output Power - OP

This parameter is the Output 1 power level. It can only be adjusted in Manual Control Mode, otherwise it is a "Read Only" parameter. The adjustment range is -100% to +100% (or 0% to +100% on Controllers which have Output 1 only). This parameter is not available on Model 3800 Controllers which have the VMD Output Option fitted.

4.3.5 Proportional Band - Pb

The Proportional Band can be set to a value between 0% and 1000% of the span of the controller. If the Proportional Band is set to 0%, the controller operates in an ON/OFF Mode.

4.3.6 Integral Time Constant - rSEt

This can be set to a value between 10 seconds and 30 minutes. If the Integral Time Constant is set to a value greater than 30 minutes, the upper display goes blank. This parameter is omitted from the sequence if the Proportional Band is set to 0%.

4.3.7 Derivative Time Constant - rAtE

This can be set to a value between 0 seconds and 10 minutes. This parameter is omitted from the sequence if Proportional Band = 0%.

4.3.8 Relative Gain - rCG

This defines the Output 2 gain relative to Output 1, within the Proportional Band and the maximum Output 2 outside the Proportional Band. It can be set to a value between .02 and 1.00. If rCG > 1.00, the upper display goes blank and Output 2 operates in an ON/OFF mode.

4.3.9 Overlap/Deadband - OL

This defines the area within the Proportional Band in which Output 1 and Output 2 are both active (0% to 20%) or the area within the Proportional Band in which Output 1 and Output 2 are both inactive (0% to -20%).

NOTE

This parameter is skipped if Proportional Band = 0%, if Output 2 is not fitted or if Output 2 is set to ON/OFF Mode (Relative Gain 1.00).

4.3.10 On/OFF Differential - diF1, diF2 or diFF

This parameter is included in the sequence only if Proportional Band = 0% or if Output 2 is set to ON/OFF Mode (Relative Gain 1.00). It applies to Output 1 and Output 2 if Proportional Band = 0%. It applies only to Output 2 if Output 2 is set to ON/OFF Mode (Relative Gain > 1.00). This parameter provides a deadband to prevent too-frequent load switching and can be set to a value between 0.1% and 10% of the span of the controller.

4.3.11 Set Point Minimum and Set Point Maximum - SPHi & SPLo

These should be set to values such that, in User Mode, the operator cannot adjust the Set Point to a value which might cause damage.

4.3.12 Remote Set Point Scale Maximum - rSPH

This parameter defines the maximum scale value of the Remote Set Point input (Terminals 12 and 13) and may be adjusted over the range -1999 to 9999 (provided that the Remote Set Point Scale Maximum is greater than the Remote Set Point Scale Minimum). The decimal point position for the Remote Set Point input scaling always corresponds to that for the process variable input range. Example: For a 0 - 20mA RSP input, this value corresponds to 20mA input.

4.3.13 Remote Set Point Scale Minimum - rSPL

This parameter defines the minimum scale value of the Remote Set Point input (Terminals 12 and 13) and may be adjusted over the range -1999 to 9999 (provided that the Remote Set Point Scale Minimum is less than the Remote Set Point Scale Maximum). The decimal point position for the Remote Set Point input scaling always corresponds to that for the process variable input range. Example: For a 0 - 20mA RSP input, this value corresponds to 0mA input.

4.3.14 Recorder Output Scale Maximum - roPH

This parameter defines the maximum scale value of the Recorder Output (Terminals 10 and 11) and may be adjusted over the range -1999 to 9999. The decimal point position for the Recorder Output scaling always corresponds to that for the process variable input range. If the Recorder Output Scale Maximum is adjusted to be less than the Recorder Output Scale Minimum, the relationship between the process variable value and the Recorder Output is reversed. Example: For a 0 - 5V recorder output, this value corresponds to 5V output.

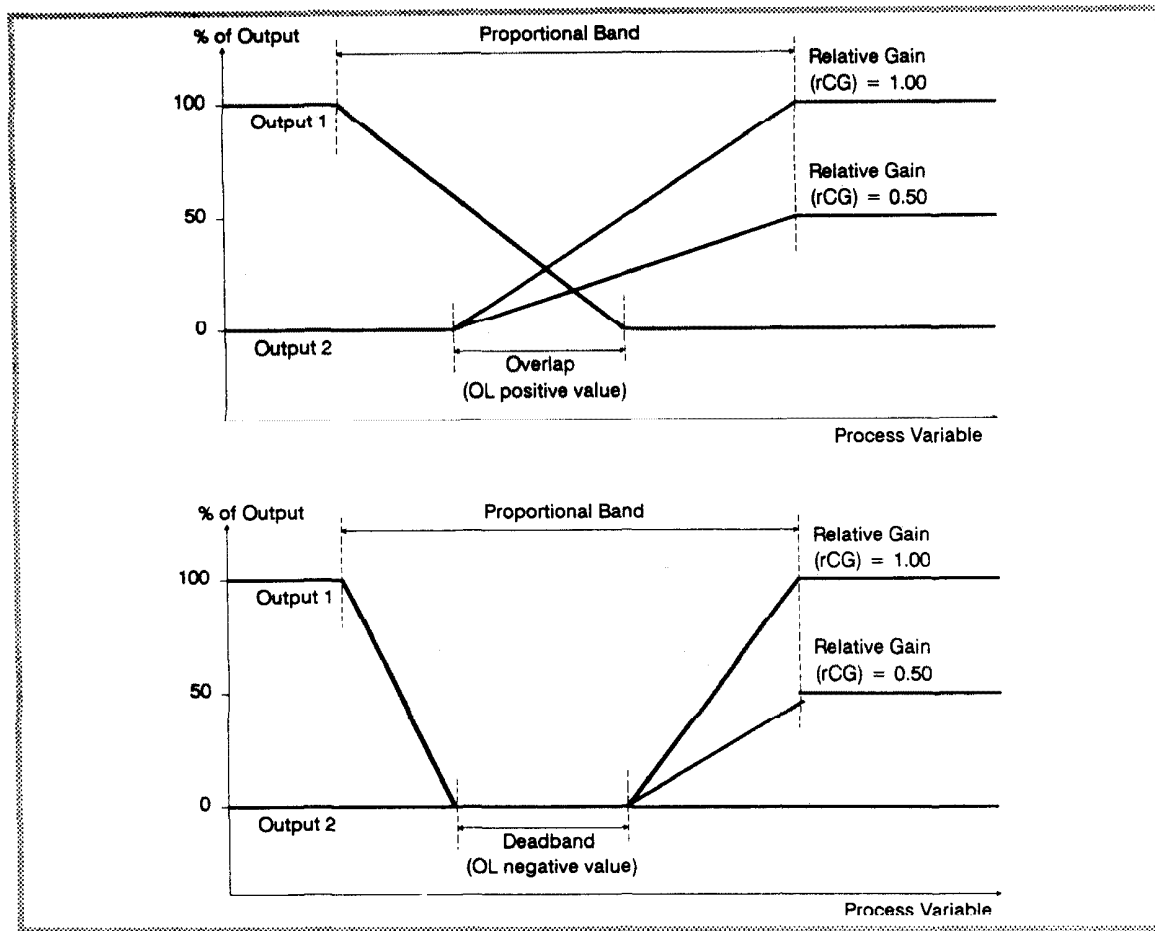

Figure 4-1 Overlap/Deadband - OP 1 and OP2 Fitted

4.3.15 Recorder Output Scale Minimum - roPL

This parameter defines the minimum scale value of the Recorder Output (Terminals 10 and 11) and may be adjusted over the range -1999 to 9999. The decimal point position for the Recorder Output scaling always corresponds to that for the process variable input range. If the Recorder Output Scale Minimum is adjusted to be greater than the Recorder Output Scale Maximum, the relationship between the process variable value and the Recorder Output is inverted. Example: For a 0 - 5V recorder output, this value corresponds to 0V output.

4.3.16 Output 1 Power Limit - OPhi

This parameter is used to limit the power level of Output 1 and may be used to protect the process. If no protection is required, this parameter may be set to 100%. This parameter is omitted from the Set-Up sequence if Proportional Band = 0%.

4.3.17 Output 1 Cycle Time - Ct1

The selection of cycle times is dependent upon the process being controlled. For relay outputs, the cycle time should be as large as possible (consistent with satisfactory control) in order to maximise relay life. If the SSR Drive Output is fitted, the cycle time may be selected from the lower values in the permitted range. The permitted range of values is:

1/2, 1, 2, 4, 8, 16, 32 and 64 seconds

This parameter is omitted from the Set-Up sequence if Proportional Band = 0%.

4.3.18 Output 2 Cycle Time - Ct2

The value of this parameter can be set in the range:

1/2, 1, 2, 4, 8, 16, 32, 64, 128, 256 and 512 seconds

This parameter is omitted from the Set-Up sequence if Proportional Band = 0%.

4.3.19 Output 2 Value - Out2

This parameter defines the switch-on and switch-off levels for Output 2 operating in ON/OFF Mode. The levels are defined as follows (for a direct-acting Output 2):

Switch-on: Set Point + Output 2 Value + 1/2 x On/Off differential.

Switch-off: Set Point + Output 2 Value - 1/2 x On/Off differential.

Note that the Output 2 Value may be negative, in which case the expressions above are still valid but Output 2 will switch on when the process variable is below the set point.

4.3.20 Process Alarm Value - P_AL

This sets the level of the process variable at which the process alarm will operate (see Subsection 4.6). This parameter will be omitted from the Set-Up sequence if the process alarm option is not fitted.

4.3.21 Band Alarm Value - b_AL

This sets the level of the process variable at which the band alarm will operate (see Subsection 4.6). This parameter will be omitted from the Set-Up sequence if the band alarm option is not fitted.

4.3.22 Deviation Alarm Value - d_AL

This sets the level of the process variable at which the deviation alarm will operate (see Subsection 4.6). This parameter will be omitted from the Set-Up sequence if the deviation alarm option is not fitted.

4.3.23 Ramping Set Point Rate - rP

This parameter defines the rate at which the Set Point may be made to ramp by the Controller. It may be set within the range 1 unit/hour - 9999 units/hour. With rP > 9999, the Ramping Set Point facility is disabled. The decimal point position for the Ramping Set Point Rate corresponds to that for the process variable input range. With the Ramping Set Point facility enabled, the ramping set point operates under the following circumstances:

(a) When the Controller is powered up; the internal set point value will ramp at the specified rate from the initial process variable value to the final set point value (i.e. that defined by LSP or rSP, as appropriate).

(b) When the set point value is changed; the internal set point will ramp at the defined rate from the original set point value to the new set point value (this may be caused either by an actual change in set point value or by a change from local set point to remote set point or vice versa).

(c) When the Controller changes from Manual Control mode to Auto Control mode; the internal set point value will ramp at the defined rate from the process variable value to the final set point value (i.e. that defined by LSP or rSP, as appropriate).

4.3.24 Motor Travel Time - tr**NOTE**

This parameter is only applicable to 3800 Controllers with VMD Open Loop Output.

This parameter defines the time taken for the motor to turn the valve from "completely open" to "completely closed" or vice versa. It can be adjusted within the range five seconds to five minutes. The default value is one minute.

4.3.25 Motor Switching Hysteresis - hYSt

NOTE

This parameter is only applicable to 3800 Controllers with VMD Open Loop Output.

This parameter defines the minimum amount of motor travel (expressed as a percentage of the total motor travel) which the VMD Open Loop output can cause. This enables minor fluctuations in the control or process conditions to be ignored, eliminating "fluttering" in the valve motor. This parameter can be adjusted within the range 0.04% to 5% of full travel. The default value is 1%.

4.3.26 Scale Range Decimal Point - rPnt

This parameter defines the position of the decimal point on the measured variable and the set point:

Value	Decimal Point Position
0	xxxx
1	xxx.x
2	xx.xx
3	x.xxx

The default value is 1. This parameter is omitted from the Set-Up sequence if the Linear Input Option is not fitted.

4.3.27 Scale Range Maximum - rhi

This parameter defines the maximum value to which the set point may be adjusted. The permitted range of this parameter is dependent upon the value of the Scale Range Decimal Position (rPnt):

Decimal Point Position	Possible Values of rhi
xxxx	(rLo + 1) to 9999
xxx.x	(rLo + 0.1) to 999.9
xx.xx	(rLo + 0.01) to 99.99
x.xxx	(rLo + 0.001) to 9.99

The default value is 100.0. This parameter is omitted from the Set-Up sequence if the Linear Input Option is not fitted.

4.3.28 Scale Range Minimum - rLo

This parameter defines the minimum value to which the set point may be adjusted. The permitted range of this parameter is dependent upon the value of the Scale Range Decimal Position (rPnt):

Decimal Point Position	Possible Values of rLo
xxxx	-1999 to (rhi - 1)
xxx.x	-199.9 to (rhi - 0.1)
xx.xx	-19.99 to (rhi - 0.01)
x.xxx	-1.999 to (rhi - 0.001)

The default value is 000.0. This parameter is omitted from the Set-Up sequence if the Linear Input Option is not fitted.

4.3.29 Auto Pre-Tune Enable/Disable - APt

The Model 3800 Controller's Pre-Tune facility can be selected for automatic execution on every power-up using this parameter (1 = enabled, 0 = disabled). Default setting is 0 (disabled).

4.3.30 Manual Control Enable/Disable - EnbL

This parameter determines whether Manual Control is enabled or disabled. Default setting is 0 (disabled).

4.4 TUNING THE CONTROLLER MANUALLY

4.4.1 Controllers Fitted with Output 1 Only

NOTE

For 3800 Controllers fitted with VMD Open Loop Output, refer to Subsection 4.4.2.

Before starting to tune the controller to the load, check that:

- Output 1 Power Limit is set to the required level (see Subsection 4.3.8).
- Set point maximum and set point minimum are set to safe levels (see Subsection 4.3.7).
- Cycle Times are set to suitable values (see Subsections 4.3.9 and 4.3.10).

The following simple techniques may be used to determine values for proportional band (**Pb**), derivative (**rAtE**) and integral (**rSEt**).

NOTE

These techniques are suitable only for processes which are not harmed by large fluctuations in the process variable. They provide an acceptable basis from which to start fine tuning for a wide range of processes. For additional information on tuning, including alternative tuning techniques, refer to the book "Principles of Temperature Control", available from WEST.

1. Set the set point to the normal operating process value (set it to a lower value if overshoot beyond the normal operating process value is likely to cause damage).
2. Set the proportional band to 0%, and On/Off Differential to 0.1% (this sets the controller to ON/OFF control and **rSEt** and **rAtE** parameters will be omitted in the Set-Up sequence).
3. Switch on the power supply to the heater. Under these conditions, the process variable will oscillate about the set point and the following parameters should be noted:
 - (a) The peak-to-peak variation (**P**) of the first cycle (i.e. the difference between the highest value of the first overshoot and the lowest value of the first undershoot).
 - (b) The cycle time (**T**) of this oscillation in minutes (see Figure 4-2).
4. The control setting should then be adjusted as follows:

$$\text{Proportional Band} = \frac{P}{\text{Scale Range}} \times 100$$

$$\text{Integral Time Constant} = T \text{ minutes}$$

$$\text{Derivative Time Constant} = T/6 \text{ minutes}$$

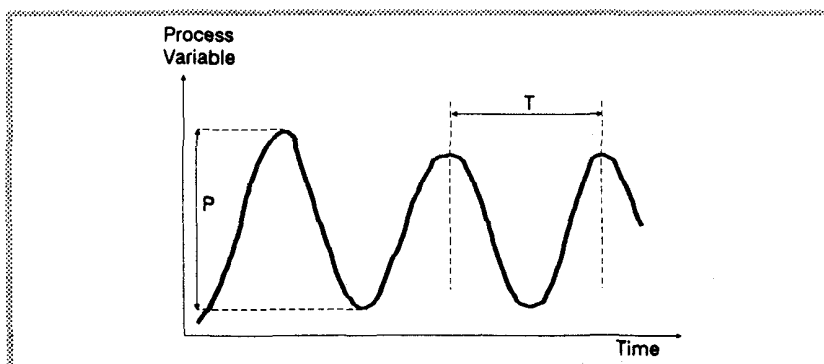

Figure 4-2 Setting-up Procedure

AFTER SETTING UP THE PARAMETERS, SET THE CONTROLLER TO USER MODE (SEE SUBSECTION 4.7) TO PREVENT UNAUTHORISED ADJUSTMENT TO THE VALUES.

4.4.2 Model 3800 Controllers with VMD Open Loop Output

Before starting to tune the controller to the load, check that the set point maximum and set point minimum are set to safe levels (see Subsection 4.3.7).

The manual tuning procedure is as follows:

1. Set the set point (SP) to below the normal operating process value (significantly lower if overshoot beyond this value is likely to cause damage).
2. Set the proportional band (Pb) to 1%, set the integral time constant (rSEt) to its maximum value (99 minutes 59 seconds) and set the derivative time constant (rAtE) to zero.
3. Set the motor travel time (tr) to the time required for the valve to travel from fully-open to fully-closed (or vice versa).
4. Set the motor switching hysteresis (hYSt) to the minimum motor travel required (expressed as a percentage of the full motor travel).
5. Follow the instructions shown in Figure 4-2, allowing sufficient time at each stage before performing the subsequent stage.

NOTE

Valve Motor Drive applications require smooth changes in power level. Derivative control action is liable to produce rapid changes and, therefore, is not desirable. This is particularly true in cases where the control loop is fast-reacting and the resultant fast switching of the valve motor drive is detrimental to the life of the relays and the valve motor

4.4.3 Controllers Fitted with Output 1 and Output 2

NOTE

Before starting to tune the controller to the load, check that:

- Output 1 Power Limit is set to the required level (see Subsection 4.3.8).
- Set Point Minimum and Set Point Maximum are set to safe levels (see Subsection 4.3.7).
- Cycle Times are set to suitable values (see Subsections 4.3.9 and 4.3.10).

In addition to the proportional band, integral and derivative, two more control parameters are provided in the Set-Up sequence:

- (a) Relative Gain (rCG)
- (b) Deadband/Overlap (OL)

The relationship between these parameters and the controller output is illustrated in Figure 4-1.

1. Set the overlap to 0.
2. Set the relative gain to 1.00.
3. With power connected to the heater, but with the machine not running, perform either of the tuning methods described in Subsection 4.4.1.
4. Start the machine and observe the oscillation (if any) of the process variable about the set point.
5. Follow the instructions in Figure 4-3.

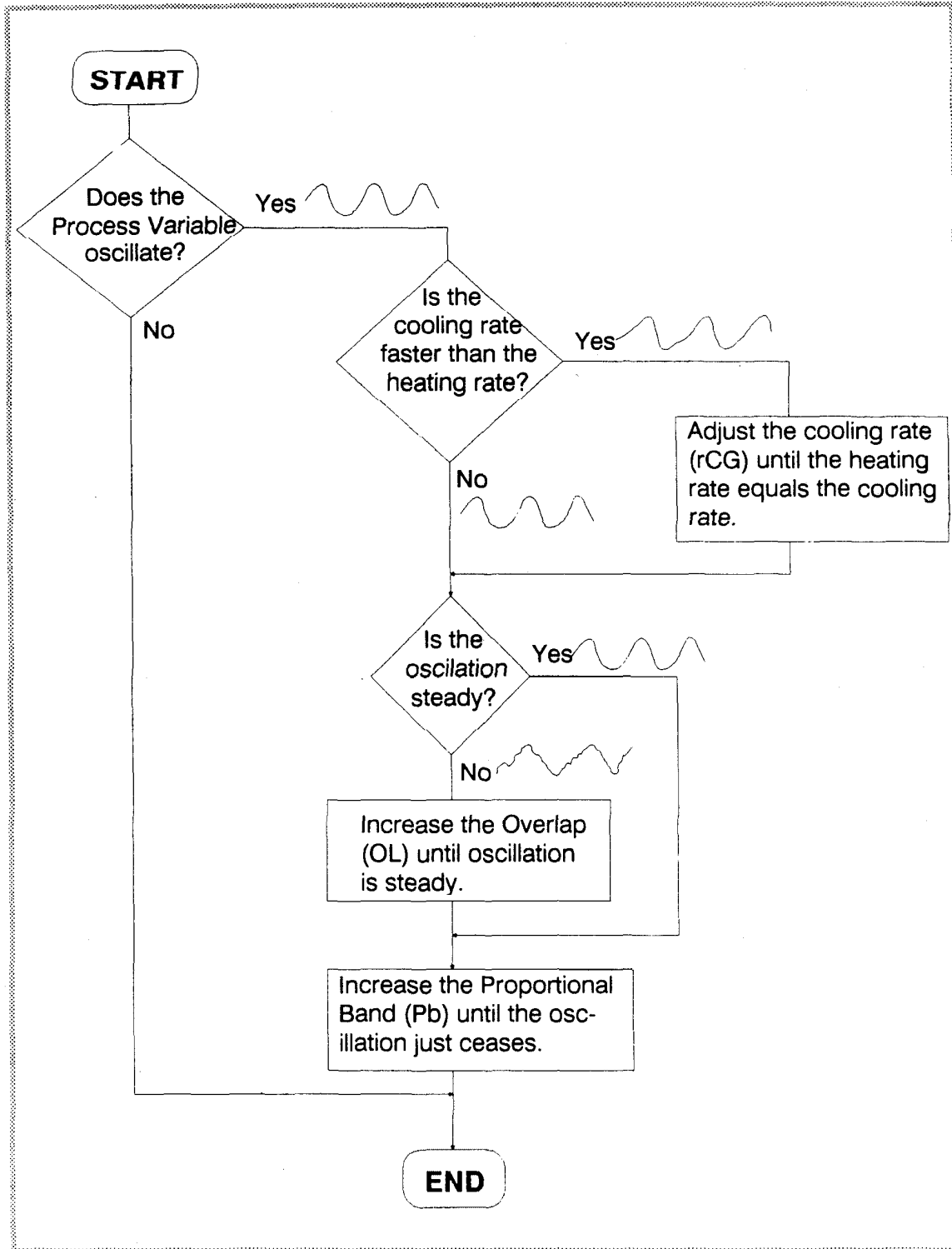

Figure 4-3 Tuning - OP 1 & OP 2 Fitted

4.5 TUNING THE 3800 CONTROLLER USING PRE-TUNE AND SELF-TUNE

4.5.1 Using the Pre-Tune Facility

The Pre-Tune facility provides a fast method of setting up the controller to the approximately correct values of Proportional Band (Pb), integral (rSEt) and derivative (rAtE). It is intended as a base from which the Self-Tune facility will implement further optimisation of these control parameters.

To select the Pre-Tune facility manually:

1. With the Controller in User Mode and Normal Display Mode (i.e. with the upper display showing the current process variable value and the lower display showing the current set point value), depress and hold simultaneously the Raise and Lower pushbuttons. After a delay of approximately five seconds, the SET indicator will start to flash.
2. When the SET indicator starts to flash, release the Raise and Lower pushbuttons and depress and hold simultaneously the Auto/Manual and FUNC pushbuttons. After a delay of approximately two seconds, the SET indicator will be extinguished and the TUNE indicator will start to flash.
3. Release the Auto/Manual and FUNC pushbuttons.

The TUNE indicator will continue to flash whilst the Pre-Tune routine is being executed. This indicator will stop flashing when the Pre-Tune routine is completed, whereupon the Controller will return to the mode in which the Controller was operating when the Pre-Tune facility was activated.

At the start of the Pre-Tune routine, the Controller applies maximum permitted Output 1 power (if the set point is above the measured variable) or maximum Output 2 power (if the set point is below the measured variable) until the measured variable is half-way between the its initial value and the set point. The Controller then applies maximum reverse power until the measured variable starts to reverse its rate of change (i.e. at the peak of an overshoot). The level and duration of the overshoot are used as a basis for calculation of appropriate values for the control parameters. If Automatic Pre-Tune on Power-Up (see Subsection 4.3.22 and Table 4-1) has been selected, the Controller will execute the Pre-Tune routine automatically on power-up in an identical manner to that when the routine is manually activated. If the value or setting of any parameter is adjusted during execution of the Pre-Tune routine, that routine will be aborted and the Controller will revert to Self-Tune mode or Manual Tune mode (whichever was selected immediately prior to activation of the Pre-Tune routine).

4.5.2 Using the Self-Tune Facility

When the Controller enters Self-Tune mode, the front panel TUNE indicator is continuously ON. In this mode, the values of the proportional band (Pb), integral (rSEt), derivative (rAtE) and relative gain (rCG) parameters cannot be adjusted by the operator. After any manual changes to control parameter values or an execution of the Pre-Tune routine, once the Controller enters the Self-Tune mode it uses the revised parameter values as a basis for optimising the control function. If no manual changes have been made to the parameter values or if the Pre-Tune routine has not been run, the Self-Tune routine uses the Controller's default parameter settings which are factory-set before delivery to user.

To select the Self-Tune facility:

1. With the Controller in User Mode and normal display mode (i.e. the upper display showing the current value of the process variable and the lower display showing the current value of the set point), depress and hold simultaneously the Raise and Lower pushbuttons. After a delay of approximately five seconds, the SET indicator will start to flash.
2. Within three seconds of the SET indicator starting to flash, release the Raise and Lower pushbuttons and depress and hold the Auto/Manual pushbutton. After a delay of approximately two seconds, the SET indicator will be extinguished and the TUNE indicator will be continuously ON.
3. Release the Auto/Manual pushbutton.

The Controller will remain in Self-Tune mode (even if powered-down then powered-up) until the Pre-Tune facility or Manual Tune Mode is selected. The Self-Tune routine, when selected, is activated whenever there is any disturbance in either the process variable or the set point or on power-up. The responses of the Controller and the measured variable are used by the Self-Tune software to adjust the values of the proportional band (**Pb**), integral (**rSEt**), derivative (**rAIE**) and relative gain (**rCG**) parameters to obtain optimum control. The adjusted values of these parameters are stored and used as a basis for any subsequent adjustments which the process may require.

4.6 ALARMS

Six possible configurations of alarm are available:

Product Code	Type	Action
C--46	Band Alarm	Relay ON inside band
C--47	Band Alarm	Relay ON outside band
C--48	Process Alarm	Direct
C--49	Process Alarm	Reverse
C--50	Deviation Alarm	Direct
C--51	Deviation Alarm	Reverse

Product codes C--46, C--47, C--50 and C--51 refer to deviation alarms. Product codes C--48 and C--49 refer to alarms with a value which is absolute i.e. not relative to the set point. For configurations C--50 and C--51, the value may be set positive or negative.

The operation of the various alarm types is shown in Figure 4-4.

4.7 LEAVING SET UP MODE

To return the Controller to User Mode:

1. Using the **FUNC** pushbutton, select display of the process variable in the upper display.
2. Simultaneously depress and hold the Raise and Lower pushbuttons until the **SET** indicator starts to flash.
3. Within three seconds of the **SET** indicator starting to flash, release the Raise and Lower pushbuttons and depress and hold the **FUNC** pushbutton until the **SET** indicator is extinguished.

The Controller is now in User Mode.

NOTE

When the Controller is in Set Up Mode, if more than one minute elapses without any pushbutton being depressed, the Controller will return automatically to the User Mode.

Product Code/Function

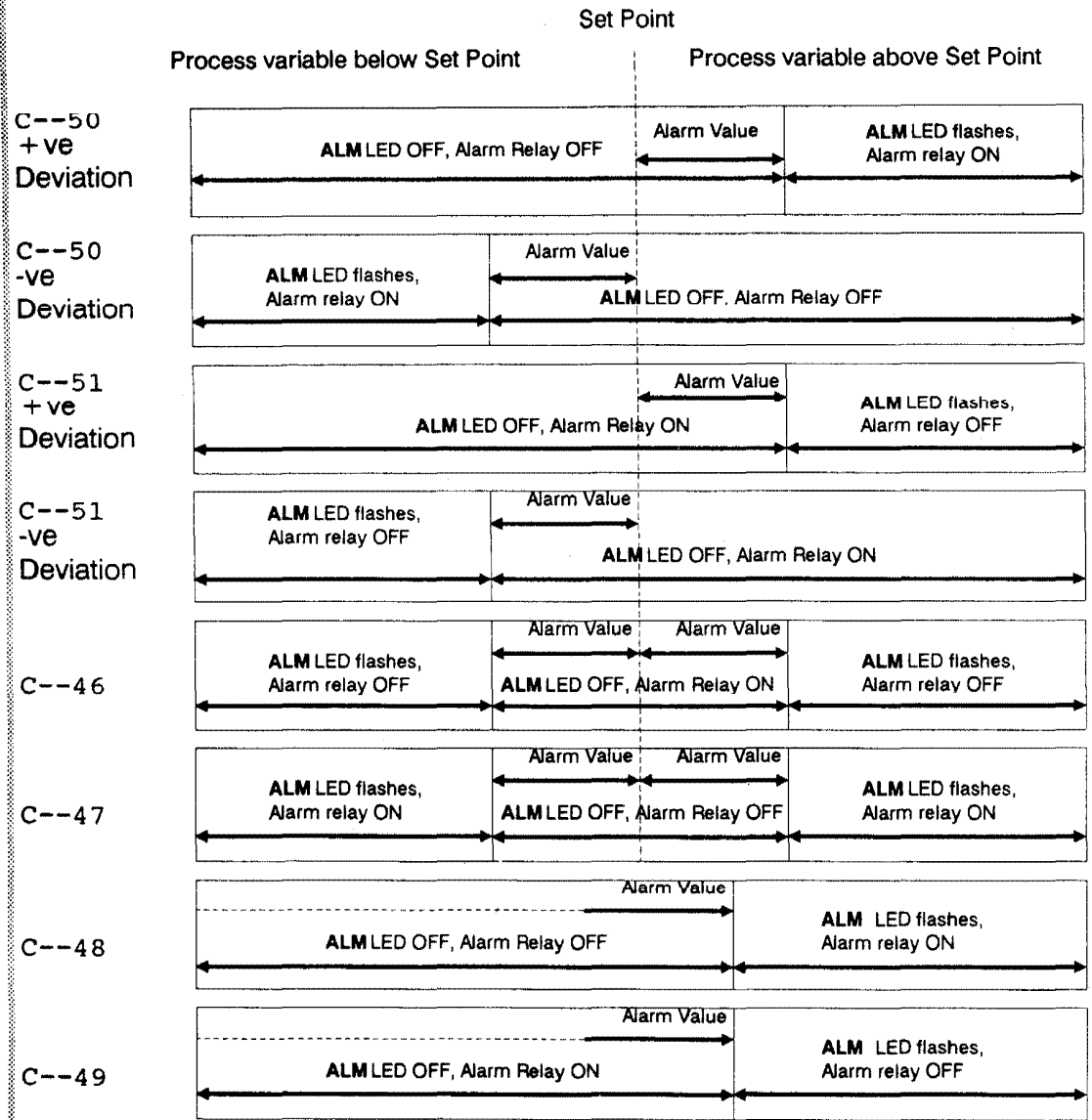

ALM LED = Controller front panel ALM indicator

Figure 4-4 Operation of Alarms

SECTION 5

OPERATION VIA AN RS485-COMPATIBLE SERIAL COMMUNICATIONS LINK

NOTE

The Communications Link is *not* available on Controllers which are fitted with either the Remote Set Point Option or the Recorder Output Option.

The WEST Model 3700 and Model 3800 Controllers may be fitted with the facility for communication with a master device (e.g. a computer or terminal) via an RS485-compatible serial link (Option X06).

5.1 RS485 CONNECTIONS

Controllers which are equipped with the RS485 Option use terminals 10, 11 and 12, as described in Subsection 2.7.9 and Figure 2-19. Communication is at 4800 Baud and the cable used should be suitable for data transfer at this frequency and for the distance required. The transmitters and receivers in the 3700/3800 Controllers conform to recommendations contained in EIA Standard RS485. Up to 32 Controllers may be connected in parallel with one master device.

5.2 ACTIVATING THE COMMUNICATIONS LINK

The two variants of Option Board which provide the RS485 Option are shown in Figures 5-1 (Option Board Type 481) and 5-2 (Option Board Type 489). These illustrations show the location of the on-board DIL switches and the link jumper positions. To activate the communications link, switch S6 must be set ON; in this state, the Controller parameters may be adjusted by the master device via the RS485 communication channel. When switch S6 is set OFF, the Controller will not adjust or change any of its parameters in response to commands received via the RS485 channel. With switch S6 in either position, the Controller will return the requested information in response to a ----? type message (see Subsection 5.4.3) from the master device.

5.3 RS485 CHANNEL SELECTION

Each 3700/3800 Controller connected to a master device has assigned to it a unique channel address which enables the master to communicate with each slave Controller individually. The channel address is defined by the setting of switches S1 - S5, thus providing up to 32 possible channel addresses for each master device. The channel addresses are defined in Table 5-1.

5.4 RS485 OPERATION

5.4.1 Character Transmission

Data characters transmitted comprise one start bit, seven data bits, one parity bit (even) and a stop bit. The link is asynchronous and operates at a transfer rate of 4800 Baud.

5.4.2 Line Turn-Round

RS485 circuits are a multi-drop half duplex system. When a device is transmitting, it drives the transmission lines to the appropriate levels; when it is not transmitting, its outputs are set to a high impedance in order that another device can transmit. It is important that a transmitter releases the transmission lines before another device starts transmission. This imposes the following restraints on a computer system communicating with the Controller(s):

- (a) The transmitter must release the transmission lines within 6 milliseconds of the end of the last character of a message being transmitted. Note that delays due to buffers such as those used in universal asynchronous receivers/transmitters (UARTs) within the computer must be taken into account.

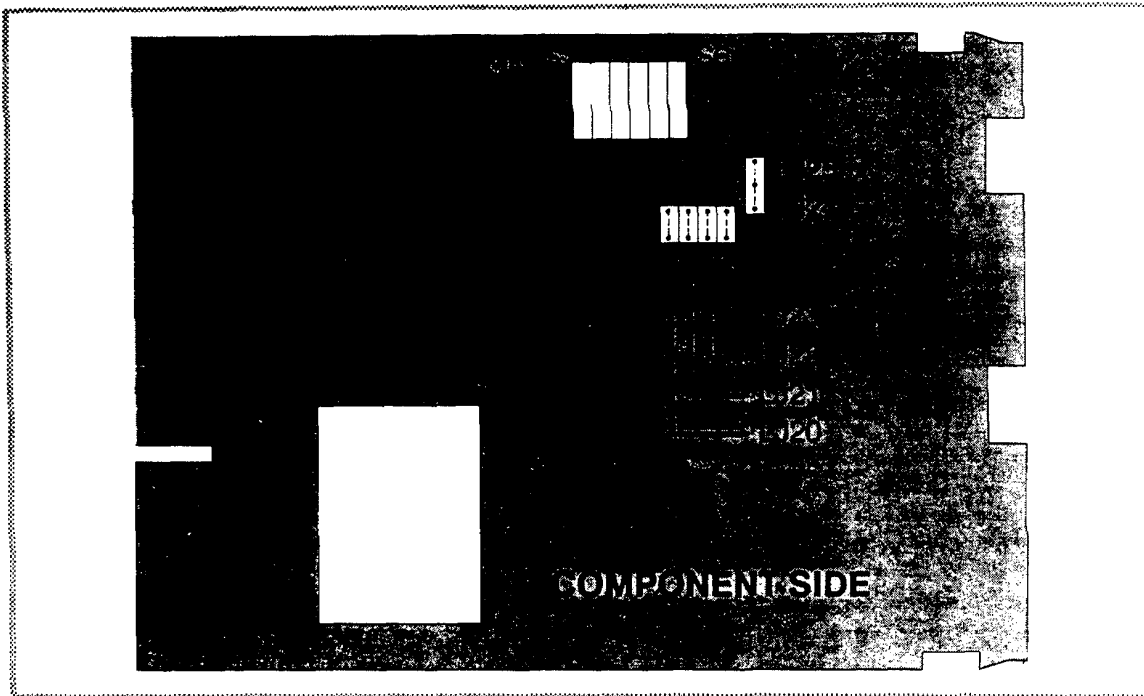

Figure 5-1 Option Board Type 481 - RS485 Switches

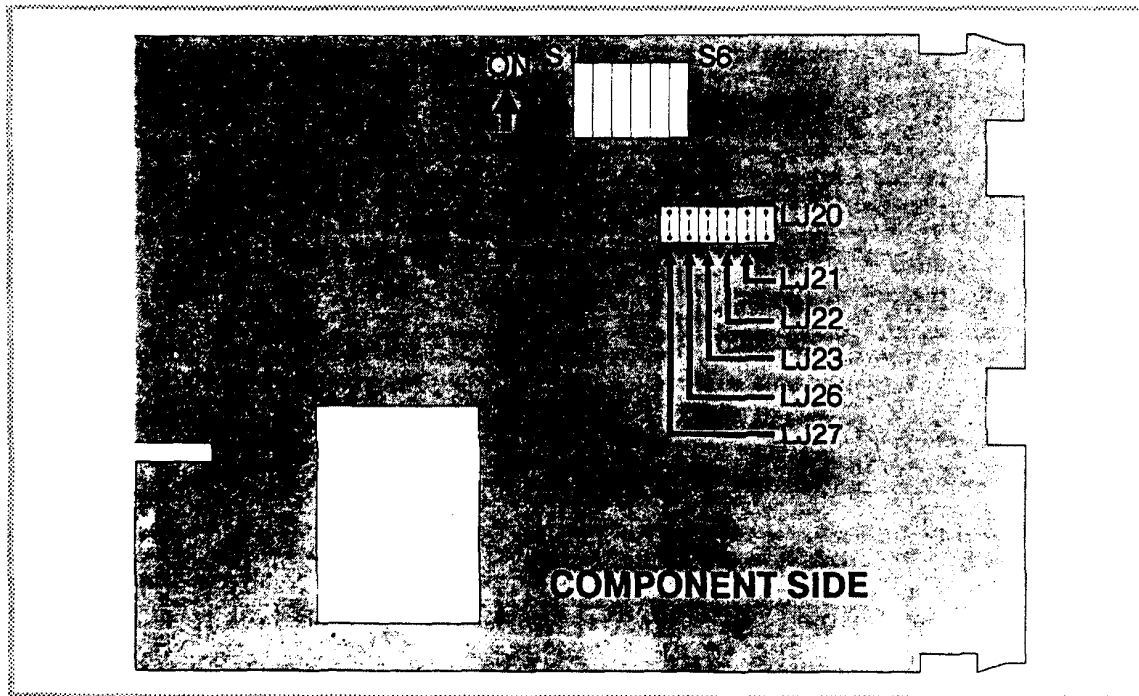

Figure 5-2 Option Board Type 489 - RS485 Switches

Table 5-1 RS485 Channel Selection

Channel No.	Switch					Channel No.	Switch				
	S5	S4	S3	S2	S1		S5	S4	S3	S2	S1
1	-	-	-	-	X	17	X	-	-	-	X
2	-	-	-	X	-	18	X	-	-	X	-
3	-	-	-	X	X	19	X	-	-	X	X
4	-	-	X	-	-	20	X	-	X	-	-
5	-	-	X	-	X	21	X	-	X	-	X
6	-	-	X	X	-	22	X	-	X	X	-
7	-	-	X	X	X	23	X	-	X	X	X
8	-	X	-	-	-	24	X	X	-	-	-
9	-	X	-	-	X	25	X	X	-	-	X
10	-	X	-	X	-	26	X	X	-	X	-
11	-	X	-	X	X	27	X	X	-	X	X
12	-	X	X	-	-	28	X	X	X	-	-
13	-	X	X	-	X	29	X	X	X	-	X
14	-	X	X	X	-	30	X	X	X	X	-
15	-	X	X	X	X	31	X	X	X	X	X
16	X	-	-	-	-	32	-	-	-	-	-

(b) The transmitter must not start transmission until at least 6 milliseconds have elapsed since the reception of the last character of a message.

All WEST Controllers which have an RS485 communications facility adhere to this standard; thus, provided that the master device conforms similarly to the standard, there should be no line contention problems.

5.4.3 Communications Protocol

All communication is initiated by the master device. The master sends a command or query to the addressed slave and the slave replies with an acknowledgement of the command or the reply to the query. All messages, in either direction, comprise:

- (a) a Start of Message character
- (b) one or two address characters (defining the slave)
- (c) a parameter/data string, and
- (d) an End of Message character

Messages from the master may be one of four types:

- Type 1:** L {N} ?? *
- Type 2:** L {N} {P} {C} *
- or
- R {N} {P} {C} *
- Type 3:** L {N} {P} # {data} *
- or
- R {N} {P} # {data} *

Type 4:

L {N} {P} I *

or

R {N} {P} I *

where all characters are in ASCII code and:

L	is the Start of Message character (Hex 4C)
{N}	is the slave controller address in the range 1 - 32; addresses 1 - 9 may be represented as a single digit (e.g. 7) or in two-digit form, the first digit being a leading zero (e.g. 07).
{P}	is the parameter to be interrogated or modified (Hex 41 - 5D) - see Table 5-2.
{C}	is the command (see below).
#	indicates that {data} is to follow. (Hex 23).
{data}	is a string of numeric data in ASCII code (see Table 5-3)
*	is the End of Message character (Hex 2A).

No spaces are permitted in messages.

Type 1 Message

L {N} ? ? *

This message is used by the master device to determine whether a slave controller is active. The reply from the addressed controller, if it is active, is:

L {N} ? A *

An inactive controller will give no reply.

Type 2 Message

L {N} {P} {C} *

This type of message is used by the master device to interrogate or modify a parameter in the addressed controller. {P} is the parameter as defined in Table 5-2 and {C} is the command, which may be one of the following:

+ (Hex 2B)	to increment the value of the parameter defined by {P}
- (Hex 2D)	to decrement the value of the parameter defined by {P}
? (Hex 3F)	to determine the current value of the parameter defined by {P}

The reply from the addressed controller is of the form:

L {N} {P} {data} A *

where {data} is five ASCII-coded digits whose meaning is shown in Table 5-3. The data is the value requested in the query or the new parameter value after modification. If the value specified is not valid, because it is outside the permitted value range of that parameter or because the parameter is not modifiable, the controller replies with a negative acknowledgement:

L {N} {P} {data} N *

The {data} string in the reply is the current (unchanged) value of the specified parameter.

If the process variable or the deviation is interrogated when the process variable is outside the range of the controller, the reply is:

L {N} {P} ?? 0 A * if over-range

or

L {N} {P} ?? 5 A * if under-range

A parameter character] in the message from the master device indicates that a "combo-scan" is required; this provides a facility for interrogating the values of set point, process variable, power output(s) and status in a single message from the master device. The reply to such a command would be in the form:

L {N}] xx aaaaa bbbbbb ccccc ddddd eeeee A *

where xx indicates the number of data digits to follow; this is 20 for an "Output 1 Only" controller and 25 for an "Output 1 and Output 2" controller. The data digits are expressed as shown in Table 5-3 and may comprise:

aaaaa	the current value of the set point
bbbbbb	the current value of the process variable
ccccc	the current value of Output 1 power (0 - 100%)
dddd	the current value of Output 2 power, if applicable (0 - 100%)
eeee	the controller status as described in Table 5-2.

Type 3 Message

L {N} {P} # {data} *

This message type is used by the master to set a parameter to the value specified in {data}. The command is not immediately implemented by the slave; the slave will receive this command and will then wait for a Type 4 message. Upon receipt of a Type 3 message, if the {data} content and the specified parameter are valid, the slave controller replies with:

L {N} {P} {data} I *

indicating that the controller is ready to implement the command. If the parameter character {P} is not alphabetic, the command is ignored. If the parameter specified is invalid or is not modifiable or if the desired value is outside the permitted range for that parameter, the controller replies with a negative acknowledgement:

L {N} {P} {data} N *

Type 4 Message

L {N} {P} I *

This is sent by the master to the addressed controller following a successful Type 3 message transmission and reply to/from the same controller. Provided that the {data} content and the parameter specified in the preceding Type 3 message are still valid, the controller will then set the parameter to the desired value and will reply with:

L {N} {P} {data} A *

where {data} is the new value of the parameter. If the new value or parameter specified is invalid, the controller will replay with a negative acknowledgement:

L {N} {P} {data} N *

where {data} is the current (unaltered) value of the parameter.

If the immediately-preceding message received by the controller was not a Type 3 message, the Type 4 message is ignored.

A leaflet giving further details of software requirements and suggestions for programs to be implemented on the master is available on request from your nearest West Division.

5.4.4 Data Format

The {data} field contains five ASCII-coded decimal digits. The first four digits form a decimal number whose sign and magnitude are defined by the value of the fifth digit, as shown in Table 5-3.

Table 5-2 Parameter Identifiers

Parameter Identifier	Parameter	Modifiable?
A	Set Point Maximum	Yes
B*	Output 1 Power Limit	Yes
C	Alarm Value	Yes
D	Derivative Time Constant	Yes
E*	On/Off Output 2 Value	Yes
F*	On/Off Differential	Yes (for Output 1 and Output 2 - if fitted - if the Proportional Band is set to 0%; for Output 2 only if Relative Gain > 1.00 i.e. Output 2 is in On/Off Mode).
G	Scale Range Maximum	Yes, if linear input fitted
H	Scale Range Minimum	Yes, if linear input fitted
I	Integral Time Constant ¹	Yes
J	Not applicable	
K*	Overlap/Deadband	Yes
L	Controller Status ²	No
M	Process Variable	No
N	Output 1 Cycle Time*	Yes
	Motor Travel Time**	Yes
O	Output 2 Cycle Time*	Yes
	Motor Hysteresis**	Yes
P	Proportional Band	Yes
Q	Range Decimal Point	Yes, if linear input fitted
R	Not applicable	
S	Set Point	Yes
T	Set Point Minimum	Yes
U*	Relative Gain ³	Yes
V	Deviation ⁴	No
W*	Output Power	Yes, if in Manual Mode
X and Y	Not applicable	
Z*	Controller Commands ⁵	Yes
]	"Combo Scan"	No
^	Ramp Rate	Yes

NOTES ON TABLE 5-2

* Not applicable to Controllers fitted with VMD Output.

** Applicable only to Controllers fitted with VMD Output.

1. To set the Integral Time Constant OFF using the Parameter Set command, the {data} field should be set to 00002.

2. The value of the status is transmitted as four decimal digits followed by 0. The four-digit number must be converted into binary form in which:

Bit 0 (the least significant bit) refers to the alarm (1 = safe; 0 = unsafe, alarm not fitted or alarm switched off).

Bit 1 is not used.

Bit 2 indicates the state of the Self Tune facility (3800 Controllers only). 1 = Enabled, 0 = disabled.

Bit 3 will be set to 1 if any programmable parameter has been changed, by means other than the communications link, since the last time access was gained to the status word.

Bit 4 indicates the status of the RS485 link (1 = enabled, 0 = disabled).

Bits 5 and 6 are not used.

Bit 7 is set to 1 if the Pre-Tune routine is in progress (3800 Controllers only).

3. To set Output 2 to ON/OFF Mode with DC or time-proportioned Output 1, the {data} field for the Relative Gain parameter should be set to 00002.

4. Deviation - (Process variable - Set Point).

5. Only Type 3 or Type 4 messages can be used with this parameter (which is applicable to 3800 Controllers only). For this type of message, the second least significant digit of the {data} field must be one of four numbers, the remaining digits being zeroes. The reply from the Controller will also contain this command number. The Type 4 message does not include the command number but the reply to the Type 4 message contains the number of the command executed. These command numbers are:

0010	Activate Manual Control
0020	Activate Automatic Control
0030	Activate Self-Tune (3800 Controllers only)
0040	De-activate Self-Tune (3800 Controllers only)
0050	Request Pre-Tune* (3800 Controllers only)
0060	Abort Pre-Tune (3800 Controllers only)

* If the process variable is within 5% of the Set Point, this command will not be implemented.

Table 5-3 {data} Field Format/Decimal Point Posn.

First Four Digits	Fifth Digit	
+abcd	0	
+abc.d	1	
+ab.cd	2	
+a.bcd	3	
+a.b.c.d.	4*	
-abcd	5	* These values indicate that default parameter values are being used.
-abc.d	6	
-ab.cd	7	
-a.bcd	8	
-a.b.c.d.	9*	

SECTION 6

RANGE-CHANGING AND RE-CONFIGURATION

It is possible to change the range of an input or output and to re-configure the Model 3700 or Model 3800 Controller by means of changing the positions of link jumpers on the CPU Board and (if fitted) the Options Board. In order to gain access to these link jumpers, it is necessary to dismantle the Controller.

NOTE

The range-changing and re-configuration operations described in this Section are confined to those which can be achieved by simply changing the positions of the appropriate link jumpers. It is not possible to change from one type of input to another or from one type of output to another, without changing the Boards. No instructions for this type of change are given in this document.

6.1 DISMANTLING THE CONTROLLER

NOTES

1. Before starting the dismantling procedure, ensure that the mains (line) supply has been disconnected.
2. The Controller contains devices which are vulnerable to damage from electrostatic discharge. In order to minimise the risk of such damage occurring during handling of the Controller and its sub-assemblies, it is recommended that certain precautions be taken:
 - (a) Never touch the tracks or components (except for link jumpers) on the PCBs.
 - (b) Before handling a PCB, momentarily touch a convenient earthing point (e.g. a metal bench or rack) in order to discharge most of the static electricity stored.
 - (c) Wear a wrist earthing strap.
3. The Controller also contains a lithium battery on the CPU Board. When removing the CPU Board from the Controller, ensure that it is not placed on a conducting surface; such contact would short-circuit the battery. **IF IT IS REQUIRED TO REPLACE THE BATTERY, THIS OPERATION SHOULD BE PERFORMED BY A TRAINED TECHNICIAN.**

6.1.1 Withdrawing the Controller from its Housing

1. With an appropriate size screwdriver (5mm or 3/16-inch flat blade), rotate the locking screw at the bottom of the Controller from panel in an anti-clockwise direction to disengage the Controller back connectors from their sockets in the housing. Continue rotating the locking screw anti-clockwise until the screw is free from its bush in the Controller housing.
2. Gently withdraw the Controller from its housing.

6.1.2 Separating the PCBs (if an Options Board is Fitted)

If the Controller has an Options Board fitted, it will be necessary to separate the two PCBs (the CPU Board and the Options Board) in order to gain access to the link jumpers. This is achieved as follows:

1. Extract the screw securing the CPU Board (on the right-hand side as viewed from the front of the Controller) to the bracket attached to the Controller front panel assembly.
2. Grasp the guides (projecting rearwards from the bottom of the front panel - see Figure 6-1) and pull them downwards until the bottom of the PCBs are released and can be withdrawn backwards; grasp the guides at the top of the front panel and disengage the top edges of the PCBs. The two PCBs may now be removed from the front panel assembly.

3. Extract the screw securing the Options Board to the pillar on the CPU Board. Carefully pull the two Boards apart, ensuring that the two Boards remain parallel to each other in order that the plugs and sockets linking the two Boards are not bent or distorted.

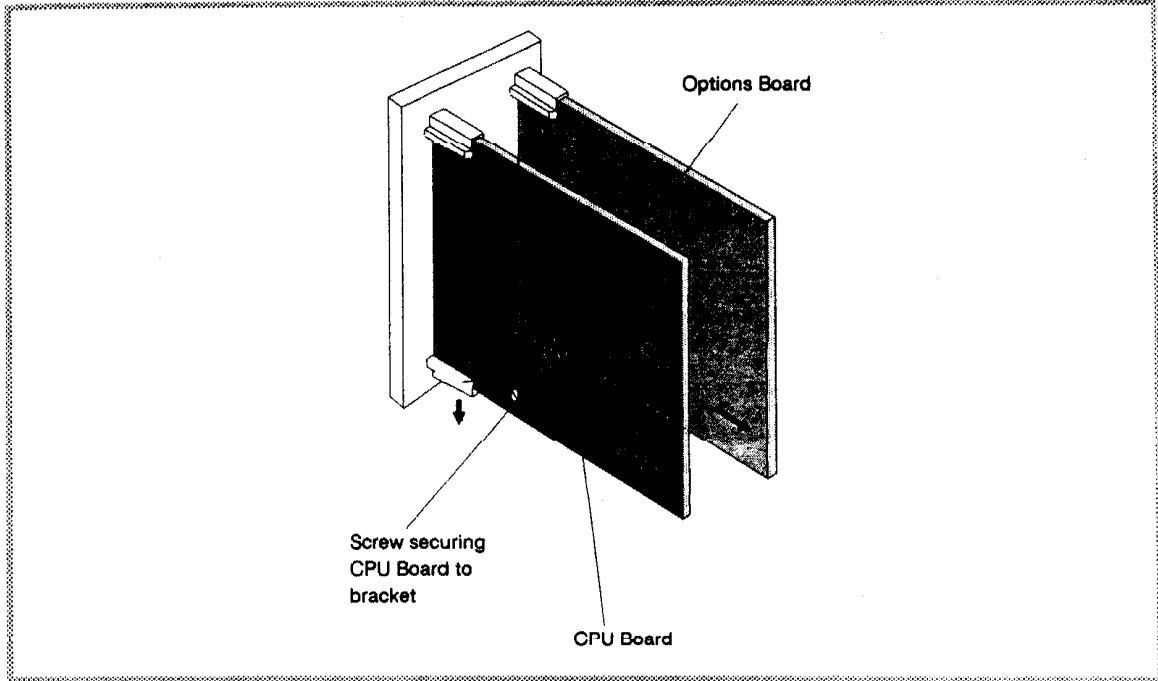

Figure 6-1 Detaching the PCBs from the Front Panel

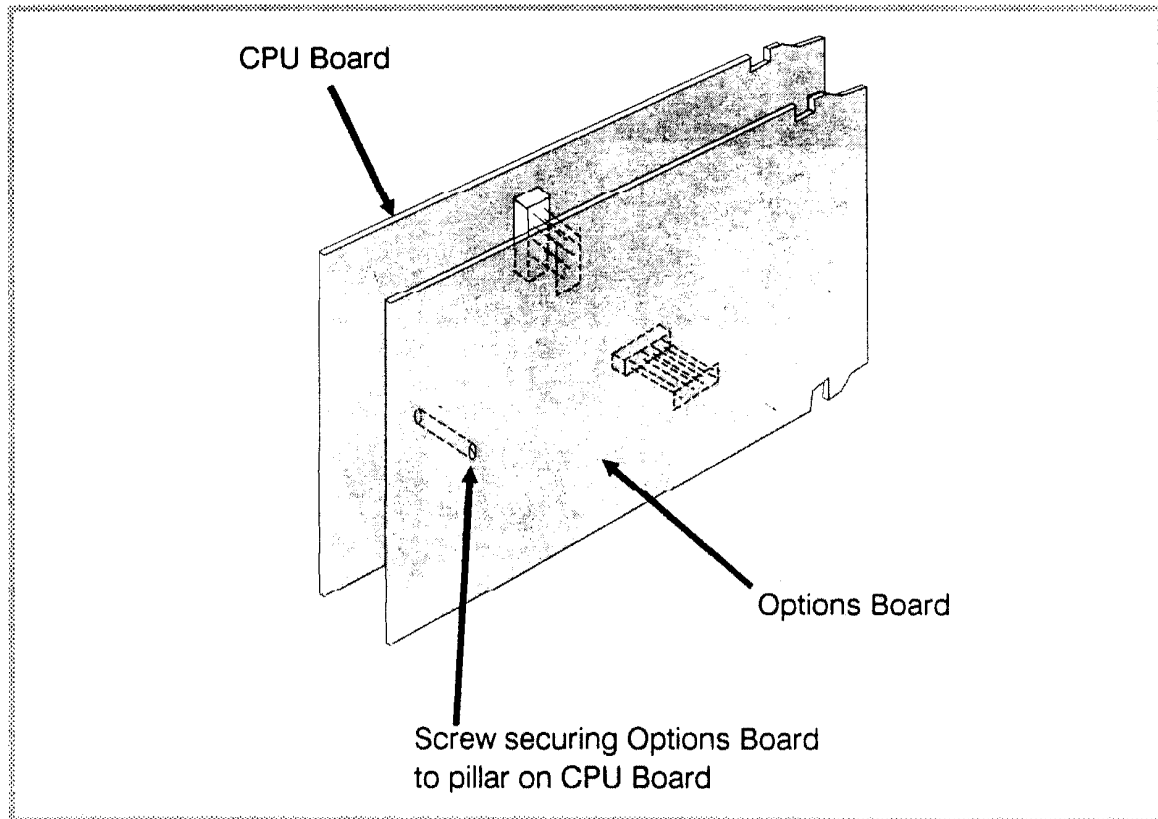

Figure 6-2 Separating the Two PCBs

6.2 CHANGING INPUT RANGES

6.2.1 Thermocouple Inputs

A Controller fitted with a thermocouple input may be re-configured to a different thermocouple input by changing jumper links on the CPU Board (see Figure 6-3) as shown in Table 6-1. Break protection link settings are shown in Table 6-2.

Table 6-1 Thermocouple Input Link Jumpers

Product Code	Input		CPU Board Link Jumpers							
	Type	Range	LJ5	LJ6	LJ7	LJ8	LJ9	LJ17	LJ18	LJ19
T1127	R	0 - 1650°C	P	X	P	X	X	X	-	X
T1128	R	32 - 3002°F	X	X	P	X	X	X	-	X
T1227	S	0 - 1650°C	P	P	X	P	P	X	-	X
T1228	S	32 - 3002°F	X	P	X	P	P	X	-	X
T1415	J	0 - 205°C	P	P	P	P	X	P	X	-
T1416	J	32 - 401°F	X	P	P	P	X	P	X	-
T1417	J	0 - 450°C	P	P	P	X	P	P	X	-
T1418	J	32 - 842°F	X	P	P	X	P	P	X	-
T1419	J	0 - 760°C	P	P	X	X	P	P	X	-
T1420	J	32 - 1400°F	X	P	X	X	P	P	X	-
T1541	T	0 - 260°C	P	X	X	X	P	X	-	X
T1542	T	32 - 500°F	X	X	X	X	P	X	-	X
T1719	K	0 - 760°C	P	P	P	X	X	P	X	-
T1720	K	32 - 1400°F	X	P	P	X	X	P	X	-
T1723	K	0 - 1731°C	P	X	P	P	P	P	X	-
T1724	K	32 - 2500°F	X	X	P	P	P	P	X	-
T1983	B	100 - 1820°C	P	P	X	P	X	X	-	X
T1984	B	212 - 3308°F	X	P	X	P	X	X	-	X
T4443*	Linear	0 - 50mV	P	P	P	P	P	P	X	-
T4499*	Linear	10 - 50mV	X	P	P	P	P	P	X	-

X = Fitted P = Parked - = Not fitted

* A Controller with a thermocouple input can be changed to 0 - 50mV or 10 - 50mV linear input, but not to any other linear input range nor to RTD input.

Table 6-2 Break Protection - Link Jumper Settings

Break Protection Type	Input Product Code	Link Jumpers	
		LJ14	LJ15
Upscale	T----	X	-
Downscale	T----21	-	X
No protection	T----22	P	-

X = Fitted P = Parked - = Not fitted

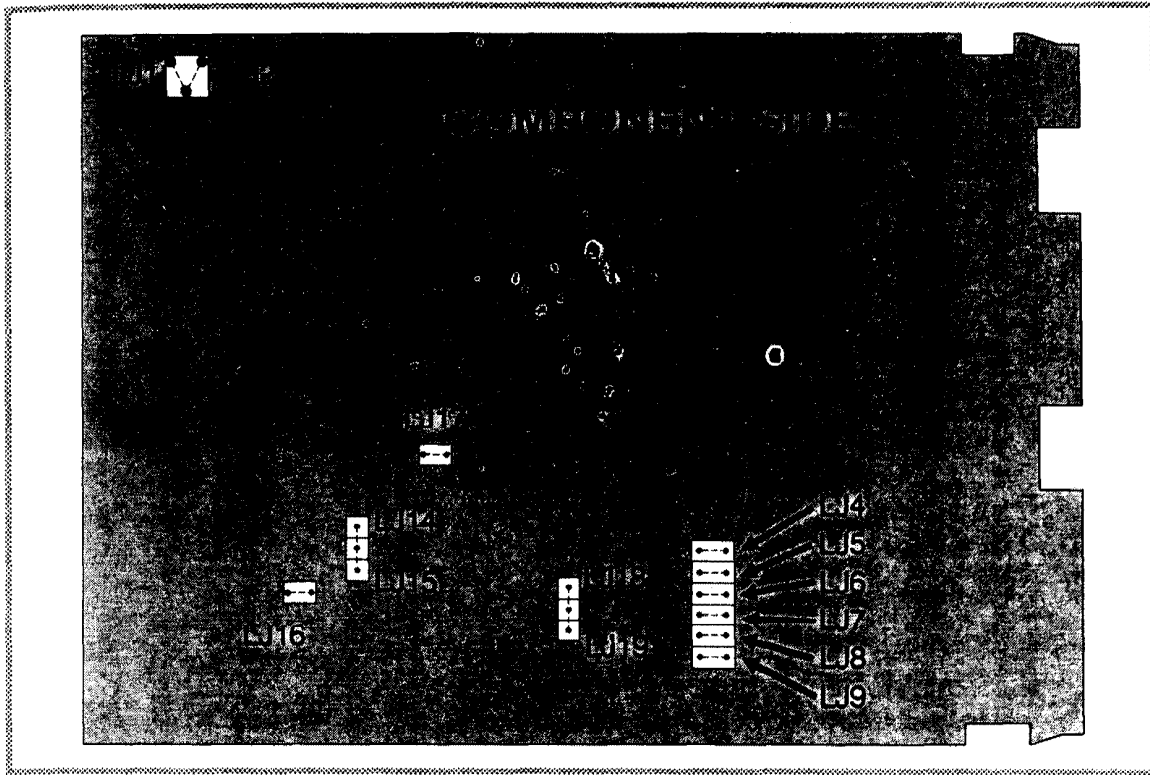

Figure 6-3 CPU Board Link Jumpers

6.2.2 RTD Inputs

A Controller equipped with an RTD Input may be re-configured to a different RTD Input by changing link jumpers on the CPU Board (see Figure 6-3) in accordance with the information in Table 6-3.

Table 6-3 RTD Input Link Jumpers

Product Code	Input Range	CPU Board Link Jumpers					
		LJ5	LJ6	LJ7	LJ8	LJ9	LJ16
T2221	0.0 to +600.0°C	P	X	X	P	X	P
T2222	+32 to 1112°F	X	X	X	P	X	P
T2229	+32 to +572°F	X	X	X	P	P	P
T2230	-101.0 to +100.0°C	P	P	X	X	X	X
T2231	-150.0 to +212.0°F	X	P	X	X	X	X
T2251	0 to +300°C	P	X	X	P	P	P
T2295	0.0 to +100.0°C	P	X	P	P	X	X
T2296	+32.0 to +212.0°F	X	X	P	P	X	X
T2297	-200 to +205°C	P	X	P	X	P	X
T2298	-328 to +401°F	X	X	P	X	P	X
T7201	-101.0 to +300.0°C	P	X	X	X	X	P
T7202	-150 to +572°F	X	X	X	X	X	P

X = Fitted

P = Parked

6.2.3 Linear Inputs

In a Controller which has a Linear Input fitted, the CPU Board will have components which are specific to that linear input range; therefore, only limited re-ranging can be achieved by changing link jumper positions. Controllers with Product Code T4443 or T4499 may be changed from one to the other and vice versa; these Controllers may also be re-configured for thermocouple input, as described in Subsection 6.2.1.

With any other linear input configurations, the only change possible by means of the link jumpers is alteration of the scale range minimum from 0% to 20% of scale range maximum and vice versa.

Table 6-4 shows the Linear Input Product Codes which can be interchanged.

Table 6-4 Linear Input Link Jumper Settings

Input Product Code	Input Range	Link Jumper LJ5
T4412	0 - 100mV	Parked
T4416	20 - 100mV	Fitted
T4444	0 - 1V	Parked
T4415	0.2 - 1.0V	Fitted
T4445	0 - 5V	Parked
T4434	1 - 5V	Fitted
T3413	0 - 20mA	Parked
T3414	4 - 20mA	Fitted

* Apart from Link Jumper LJ5, no other link jumpers should be altered.

6.3 CHANGING THE ACTION OF OUTPUT 1

Output 1 (Relay, SSR or DC output) may be configured to be direct-acting or reverse-acting:

Reverse-Acting: Output 1 is reverse-acting if the Output is active (e.g. relay energised) when the process variable value is less than the set point value.

Direct-Acting: Output 1 is direct-acting if the Output is active (e.g. relay energised) when the process variable value is more than the set point value.

For a direct-acting Output 1 (Product Code H--31), link jumper LJ4 should be fitted on the CPU Board. For a reverse-acting Output 1 (the standard configuration), link jumper LJ4 on the CPU Board should be parked.

6.4 OUTPUT 2 AND ALARM OUTPUTS

The Standard Options Board (Type 450), if fitted, provides Output 2 and/or an Alarm Output. This Options Board is supplied in one of five forms:

Configuration	Product Code
Output 2 Relay, no Alarm Output	C10
Output 2 SSR, no Alarm Output	C50
Output 2 Relay with Alarm Output	C10--
Output 2 SSR with Alarm Output	C50--
Alarm Output Only (no Output 2)	C00--

The action of Output 2 is always the opposite of that for Output 1 (i.e. if Output 1 is reverse-acting, Output 2 is direct-acting, or vice versa). If Output 2 is to be used, link LJ20 on the Options Board (see Figure 6-4) should be fitted. If Output 2 is not to be used, link LJ20 should be parked. To change the action of the Alarm Output, links on the options Board should be fitted in accordance with the information in Table 6-5. Refer to Subsection 4.6 for details of Alarm Output operation.

Table 6-5 Alarm Output Link Jumper Settings

Link Jumpers				* If Alarm Output is not supplied, link jumpers LJ21, LJ22 and LJ23 are omitted. X = Fitted P = Parked
Product Code	LJ21	LJ22	LJ23	
C--50	X	P	P	
C--51	X	P	X	
C--46	P	X	X	
C--47	P	X	P	
C--48	X	X	P	
C--49	X	X	X	
C--00*	P	P	P	

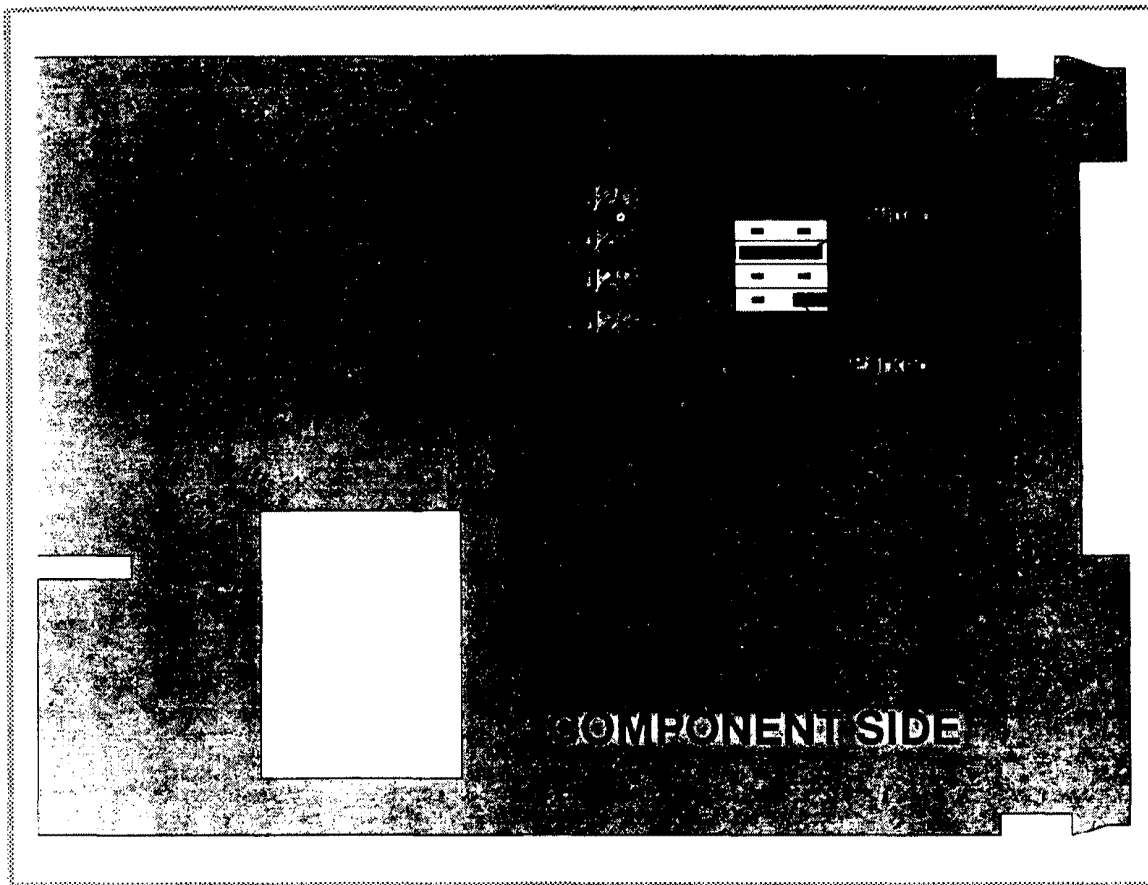
**Figure 6-4 Options Board 450 - Link Jumpers**

6.5 DC OUTPUTS (WITHOUT X06 OPTION)

The DC Output Options Board (Type 468) provides a DC output for Output 1 or Output 2 (but not both). This Board can be supplied with or without Alarm Output. When the Alarm Output is fitted, the Alarm Output functions are identical to those for the Standard Options Board (Type 450). The DC outputs are configured using link jumpers on the DC Output Options Board (see Figure 6-5 and Table 6-6). The required Alarm configuration is selected by link jumpers LJ21, LJ22 and LJ23 on the DC Output Options Board, as shown in Table 6-5.

Table 6-6 Options Board 468 - Link Jumper Settings

Product Code	Link Jumpers					X = Fitted P = Parked * = Fit if Controller has Output 2 C10 or C50 fitted.
	LJ20	LJ24	LJ25	LJ26	LJ27	
H21	*	P	P	X	X	
H24	*	X	P	X	X	
H61	*	P	X	X	X	
H64	*	X	X	X	X	
C21	X	P	P	P	X	
C24	X	X	P	P	X	
C61	X	P	X	P	X	
C64	X	X	X	P	X	

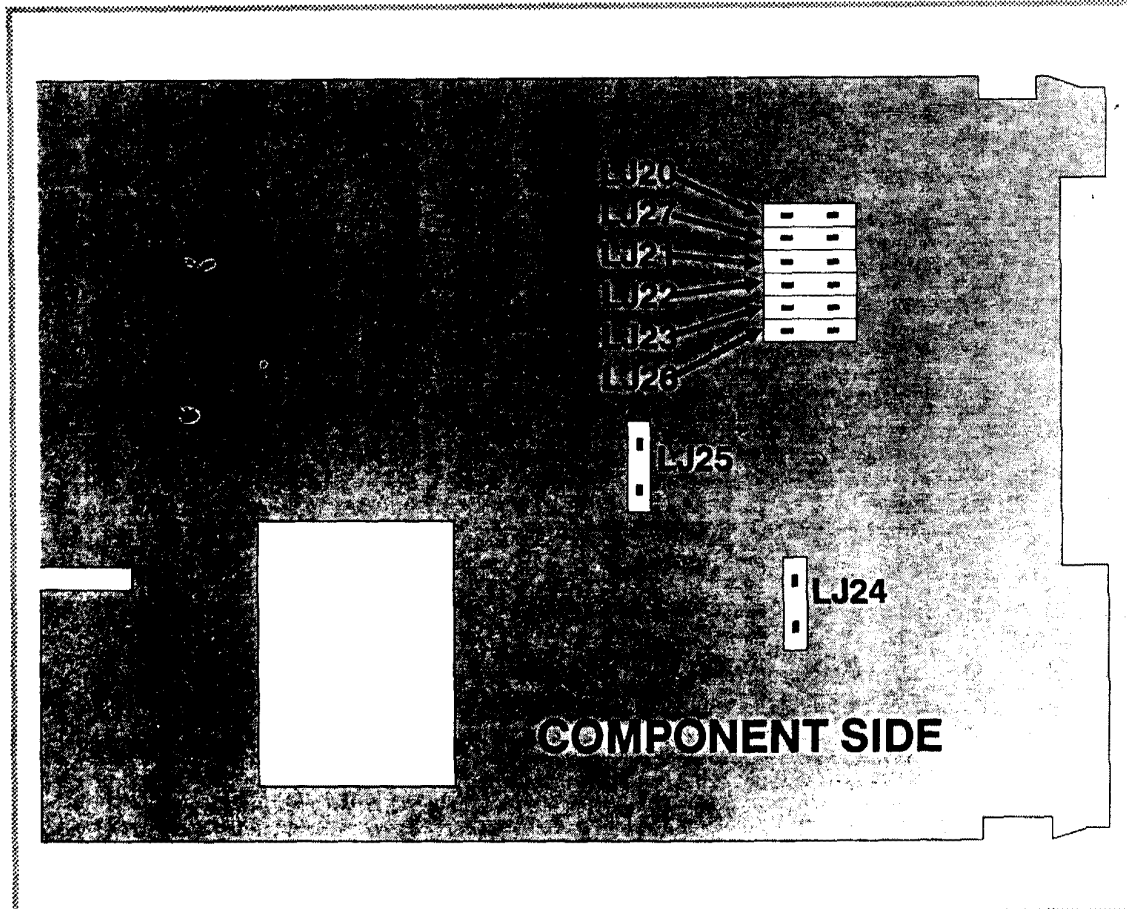

Figure 6-5 Options Board 468 - Link Jumpers

DC output is selected for Output 1 or Output 2 using link jumpers on the DC Output Options Board (see Figure 6-5 and Table 6-6). The range of the DC Output can be changed by moving link jumpers on the Board as shown in Table 6-6. DC Output 1 is reverse-acting unless link LJ4 is fitted on the CPU Board (see Subsection 6.3); DC Output 2 is direct-acting unless link LJ4 is fitted on the CPU Board.

6.6 RS485 COMMUNICATIONS OPTIONS BOARD (TYPE 481)

This Options Board is supplied in one of four forms:

- (1) Communications Option + Output 2 Relay: Code C10 X06
- (2) Communications Option + Output 2 SSR: Code C50 X06
- (3) Communications option + Alarm Output: Code C00-- X06
- (4) Communications Option only: Code C00 X06

Figure 6-6 shows the switches and link jumpers on the RS485 Communications Options Board. When an option is not supplied, the associated link jumpers will not be fitted to the Board. If an Alarm Output is supplied, the operation of that Alarm Output is defined by the configuration of link jumpers LJ21, LJ22 and LJ23 (see Table 6-5 and the "C00--" entry in Table 6-7). If Output 2 is supplied, its action (direct or reverse) is the opposite of that for Output 1. The link jumper configurations to select Output 2 or Alarm Output are shown in Table 6-7. Switch functions are described in Section 5.

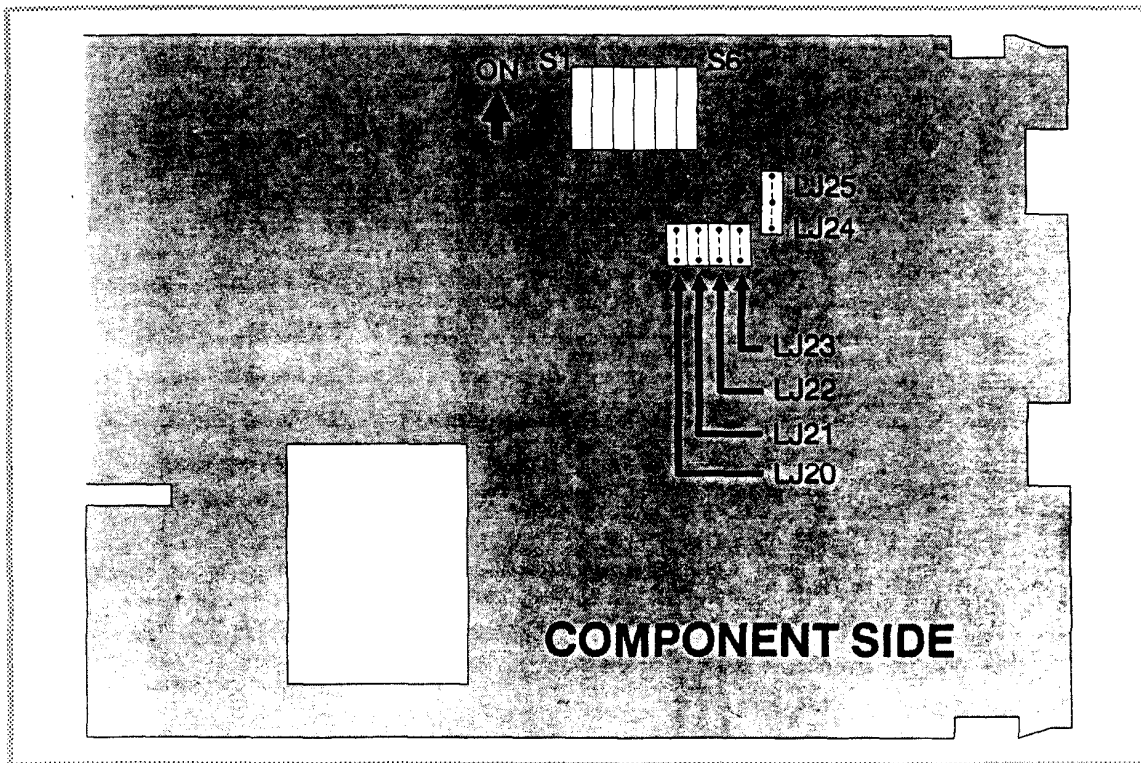

Figure 6-6 Options Board 481 - Link Jumpers

Table 6-7 OP 2/Alarm Output - Link Jumper Settings

Product Code	Link Jumpers		
	LJ20	LJ24	LJ25
C0000	P	P	-
C1000	X	X	-
C5000	X	X	-
C00--	P	-	X

6.7 DC OUTPUT/RS485 COMMUNICATIONS OPTIONS BOARD (TYPE 489)

This Options Board provides both an RS485-compatible communications link and a DC output for either Output 1 or Output 2 (but not both). The following combinations are available:

- (1) Communications Option + Output 2 Relay: Code C10 X06
- (2) Communications Option + Output 2 SSR: Code C50 X06
- (3) Communications option + Alarm Output: Code C00-- X06
- (4) Communications Option only: Code C00 X06

The selection of DC Output 1 or DC Output 2, the output ranges and the Alarm function are defined by means of link jumpers on this Options Board. Figure 6-7 shows the link jumper positions on the Type 489 Board and Tables 6-8 and 6-9 show the link jumper settings for the various configurations. Switch functions are described in Section 5.

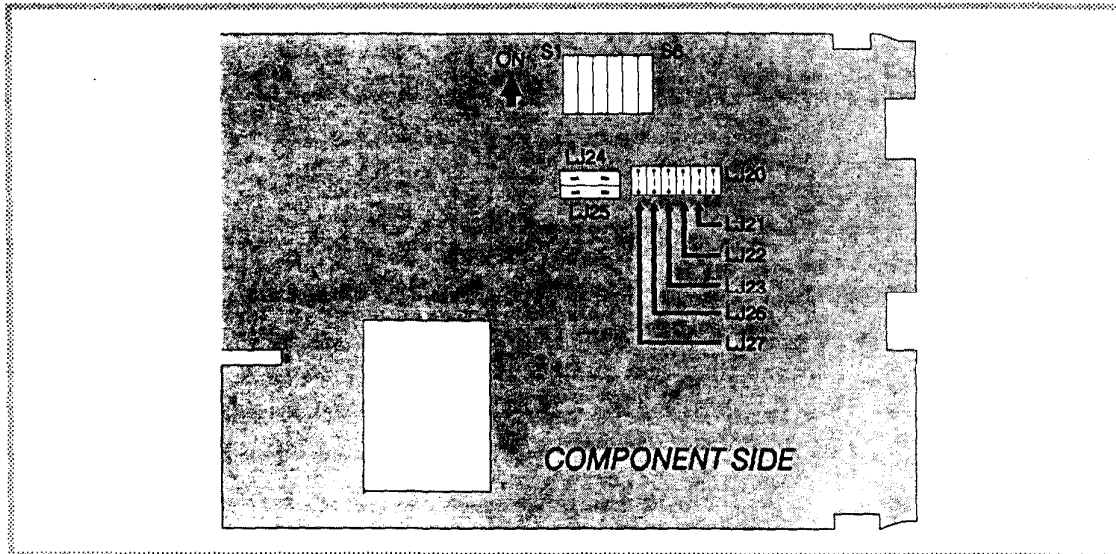

Figure 6-7 Options Board 489 - Link Jumpers

Table 6-8 Options Board 489 - DC Output Jumpers

Product Code	Link Jumpers								
	LJ20	LJ24	LJ25	LJ26	LJ27	LJ21	LJ22	LJ23	
H21	*	P	P	**	X	See Table 6-9			
H24	*	X	P	**	X				
H61	*	P	X	**	X				
H64	*	X	X	**	X				
C2100	*	P	P	**	X	P	P	P	
C2400	*	X	P	**	X	P	P	P	
C6100	*	P	X	**	X	P	P	P	
C6400	*	X	X	**	X	P	P	P	

X = Fitted

P = Parked

* Fit link LJ20 if Output 1 and Output 2 are required; otherwise park LJ20.

** Fit link LJ26 if Relay or SSR Output 2 (Code C10 or C50) is required; otherwise park LJ26.

Table 6-9 Option Board LJ Settings for CPU Board O/P

Product Code	Link Jumpers			
	LJ21	LJ22	LJ23	
H10	P	P	P	Output type (Relay or SSR) is determined by components fitted on the CPU Board.
H50	P	P	P	
C1000	P	P	P	
C5000	P	P	P	
C0000	P	P	P	Output on the CPU Board not used.
C0050	X	P	P	Standard Alarm Output requires the use of a CPU Board with Relay output.
C0051	X	P	X	
C0046	P	X	X	
C0047	P	X	P	
C0048	X	X	P	
C0049	X	X	X	

X = Fitted P = Parked

6.8 OPTIONS BOARD 496

This Options Board provides the controller with Remote Set Point Input, Recorder Output and Relay/SSR Output. *The RS485 Communications Link Option is not available when this Options Board is fitted.* The following combinations are available (in addition to the process input and Output 1):

- (1) Alarm or Output 2 Relay + Remote Set Point Input and/or Recorder Output
- (2) SSR Output 2 + Remote Set Point Input and/or Recorder Output
- (3) Remote Set Point Input and/or Recorder Output
- (4) VMD Output + Remote Set Point Input and/or Recorder Output

The selection of Output 2 type, the Alarm relay, the Remote Set Point Input option and the Recorder Output option is defined by link jumpers on the Options Board. The locations of the link jumpers are shown in Figure 6-8 and the available link jumper settings are shown in Table 6-10.

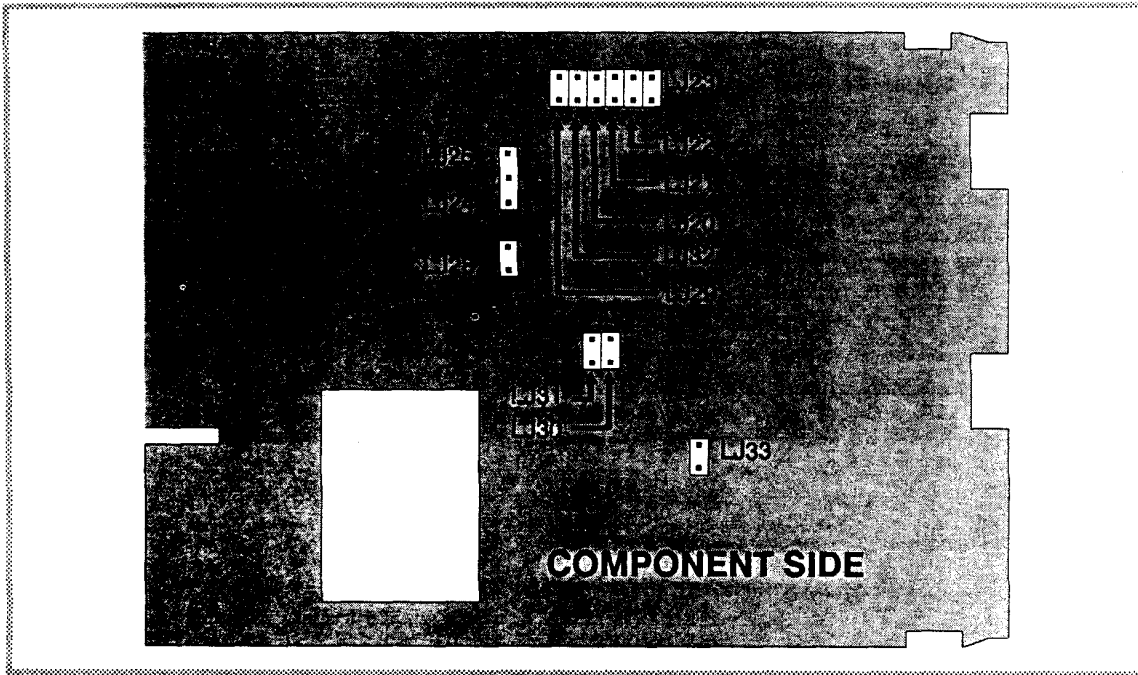

Figure 6-8 Options Board 496 - Link Jumpers

Table 6-10 Options Board 496 - Link Jumper Settings

Product Code	Link Jumpers					
	LJ20	LJ21	LJ22	LJ23	LJ24	LJ25
C00	P	P	P	P	-	X
C10	X	P	P	P	X	-
C50	X	P	P	P	X	-
C0046	P	P	X	X	-	X
C0047	P	P	X	P	-	X
C0048	P	X	X	P	-	X
C0049	P	X	X	X	-	X
C0050	P	X	P	P	-	X
C0051	P	X	P	X	-	X
H70C0000*	P	P	P	P	X	-

* Special software required.

Product Code	LJ28	LJ29	LJ30	LJ31	Product Code	LJ32	LJ33
X04	*	P	X	P	X12	P	X
X05	*	X	P	X	X18	P	P
X37	*	P	P	X	X19	X	P
X38	*	X	X	P	X20	X	X
RSP I/P OFF	P	P	P	P	Recorder O/P OFF	P	P

* Fit LJ28 if Remote Set Point only is required; otherwise park (X-40)

P = Parked X = Fitted - = Not fitted

6.9 OPTIONS BOARD 497

This Options Board provides the controller with Remote Set Point Input, Recorder Output and DC Output. *The RS485 Communications Link Option is not available when this Options Board is fitted.* The following combinations are available (in addition to process input and Output 1):

- (1) DC Output 1 + Relay/SSR Output 2 + Remote Set Point Input and/or Recorder Output
- (2) DC Output 1 + Alarm + Remote Set Point Input and/or Recorder Output
- (3) Relay/SSR Output 1 + DC Output 2 + Remote Set Point Input and/or Recorder Output

The selection of output type, alarm type, the Remote Set Point Input option and the Recorder Output option is defined by link jumpers on the Options Board. The locations of the link jumpers are shown in Figure 6-9 and the available link jumper settings are shown in Table 6-11.

6.10 CHANGING THE MAINS (LINE) SUPPLY VOLTAGE

On the CPU Board, link jumper LJ1 is fitted for operation on a 193V - 264V supply (Code L01) and link jumper LJ2 is fitted for operation on a 100V - 132V supply (Code L02). It is not possible to re-configure the Controller to/from 24V operation (Code L04).

6.11 ASSEMBLING THE CONTROLLER

6.11.1 Fitting the Options Board to the CPU Board (if required)

1. Hold the two boards side-by-side with the component sides facing each other and the PC connectors aligned.
2. Carefully align the multiple-pin plugs on the Options Board with the sockets on the CPU Board and gently engage the plugs and sockets.
3. Insert the screw (made available during the previous separation of the two boards) through the hole in the Options Board into the pillar on the CPU Board and tighten until both boards are secured together.

6.11.2 Fitting the Boards to the Front Panel Assembly

1. Align the boards with the guides attached to the front panel; the CPU Board (the one with a transformer) should be on the right-hand side when viewed from the front. Ensure that the plugs on the CPU Board are aligned with the sockets on the front panel assembly.
2. Push the boards into the guides until all the teeth on the boards locate firmly into the holes in the guides.
3. Insert the screw (made available during the previous dismantling of the Controller) through the CPU Board into the bracket attached to the front panel; tighten the screw to secure the boards in position.

6.11.3 Fitting the Controller into the Housing

1. Carefully slide the Controller, rear end first, into the housing, ensuring that the circuit board(s) locate against the outside of the guides moulded into the top and bottom of the housing.
2. Push the Controller firmly into position in order that the rear connectors of the circuit board(s) make good connection with the terminals at the rear of the housing.
3. Engage the locking screw (at the bottom of the front panel) in its bush in the housing and tighten until the Controller is secured in its housing.

Table 6-11 Options Board 497 - DC Output Link Jumpers

Product Code	Link Jumpers						
	LJ20	LJ24	LJ25	LJ26	LJ21	LJ22	LJ23
H21	*	P	P	**	See Table 6-12		
H24	*	X	P	**			
H61	*	P	X	**			
H64	*	X	X	**			
C2100	*	P	P	**	P	P	P
C2400	*	X	P	**	P	P	P
C6100	*	P	X	**	P	P	P
C6400	*	X	X	**	P	P	P

X = Fitted

P = Parked

* Fit Link LJ20 if Output 1 and Output 2 are required; otherwise park.

** Fit Link LJ26 if Relay or SSR Output 2 (Code C10 or C50) is required; otherwise park.

Table 6-12 Option Board 497 - LJs for CPU Board O/P

Product Code	Link Jumpers			
	LJ21	LJ22	LJ23	
H10	P	P	P	Output type (Relay or SSR) is determined by components fitted on the CPU Board.
H50	P	P	P	
C1000	P	P	P	
C5000	P	P	P	
C0000	P	P	P	Output on the CPU Board not used.
C0050	X	P	P	Standard Alarm Output requires the use of a CPU Board with Relay output.
C0051	X	P	X	
C0046	P	X	X	
C0047	P	X	P	
C0048	X	X	P	
C0049	X	X	X	

X = Fitted

P = Parked

Table 6-13 Options Board 497 - Option Selection

Product Code	Link Jumpers				Product Code	Link Jumpers	
	LJ28	LJ29	LJ30	LJ31		LJ32	LJ33
X04	*	P	X	P	X12	P	X
X05	*	X	P	X	X18	P	P
X37	*	P	P	X	X19	X	P
X38	*	X	X	P	X20	X	X
RSP I/P OFF	*	P	P	P	Recorder O/P OFF	P	P

* Fit link jumper LJ28 if Remote Set Point only is required (X-40); otherwise park.

P = Parked

X = Fitted

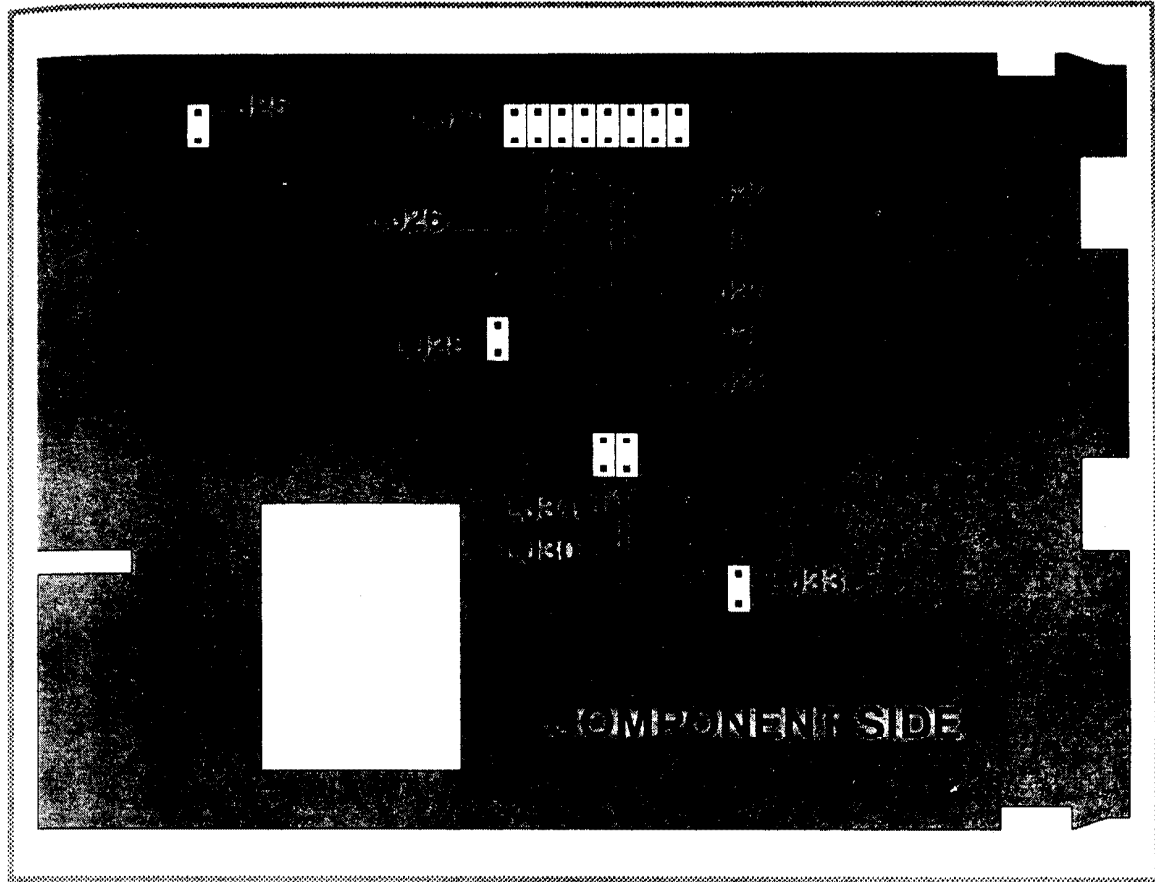

Figure 6-9 Options Board 497 - Link Jumpers

APPENDIX A

SPECIFICATION FOR 3700/3800 CONTROLLERS

INPUT

Input Types:	Thermocouple, Resistance Temperature Detector (RTD) and DC Linear.
Common Mode Rejection:	Negligible effect up to 264V 50/60Hz.
Series Mode Rejection:	1000% of span (at 50/60Hz) causes negligible effect.
Thermocouple Break Protection:	Upscale (standard), downscale (optional) or none (optional).
Thermocouple Calibration:	Complies with BS4937, NBS125 and IEC584 standards.
RTD (Pt100) Calibration:	Complies with BS1904 and DIN43760 standards.

REMOTE SET POINT INPUT (OPTIONAL)

Input Ranges:	4 - 20mA
	0 - 20mA
	1 - 5V
	0 - 5V
Input Impedance:	100 ohms (4 - 20mA and 0 - 20mA)
	200 kilohms (1 - 5V and 0 - 5V)

OUTPUTS

Output 1

Relay:	SPDT, contact rating 5A resistive @ 120V/240V AC. Relay life 10^6 operations.
Solid State Relay (SSR) Drive:	0V - 12V nominal, 18V maximum. Output impedance 250 Ω .

Output 2 (Optional)

Relay:	SPDT, contact rating 2A resistive @ 120V/240V AC. Relay life 10^6 operations.
Solid State Relay (SSR) Drive:	0V - 12V nominal, 18V maximum. Output impedance 250 Ω .

DC Output (Optional)

The DC Output option may be fitted either on Output 1 or on Output 2, but not both. The output is normally isolated to withstand up to 260V (it is non-isolated if the RS485 Communications Option - Option X06 - is fitted). There are four variants of the DC Output option:

1. 4mA - 20mA nominal; maximum load = 500 Ω
2. 0mA - 20mA nominal; maximum load = 500 Ω
3. 1V - 5V nominal; minimum load = 50k Ω
4. 0V - 5V nominal; minimum load = 50k Ω

Recorder Output (optional)

Output Range:	4 - 20mA or 0 - 20mA into 500 ohms maximum. 1 - 5V or 0 - 5V; output impedance = 250 ohms
Resolution:	> 10 bits
Accuracy:	±0.5% of span
Temperature Stability:	±0.025%/°C

Alarm Output (Optional)

Alternative configurations:

Alarm Type	Relay Energised	ALM LED Flashes
Process High Alarm (Fail-safe)	PV below alarm value	PV above alarm value
Process High Alarm	PV above alarm value	PV above alarm value
Band Alarm	PV within deviation band	PV outside deviation band
+ve deviation direct-acting	PV > (SP + deviation)	PV > (SP + deviation)
-ve deviation direct-acting	PV < (SP - deviation)	PV < (SP - deviation)
+ve deviation reverse-acting	PV < (SP + deviation)	PV > (SP + deviation)
-ve deviation reverse-acting	PV > (SP - deviation)	PV < (SP - deviation)
Relay:	SPDT, contact rating 2A resistive @ 120V/240V AC. Relay life 10 ⁶ operations.	

RS485 COMMUNICATIONS LINK

Three-wire transmit/receive connections, driven from an isolated power supply. Transmitters and receivers conform to EIA Standard RS485.

CONTROL

Self-Tune/Pre-Tune Facilities:	Automatic adjustment of: Proportional Band Integral Time Constant Derivative Time Constant Relative Gain
Set Point Ramp facility:	On power-up or when the set point value changes, the set point will ramp at an operator-defined rate in the range 1 - 9999 units/hour. Can be enabled/disabled during set-up.
Proportional Band:	0% - 1000% of span. (1% - 1000% of span for 3800 Controller with VMD Open Loop Option fitted).
Cycle Time	
- Output 1:	1/2, 1, 2, 4, 8, 16, 32 or 64 seconds.
- Output 2:	1/2, 1, 2, 4, 8, 16, 32, 64, 128, 256 or 512 seconds.
Relative Gain:	0.02 x Output 1 to 1 x Output 1 and ON/OFF (1.00)
Overlap/Deadband:	-20% to +20% of Proportional Band.

Integral Time Constant:	10 seconds - 30 minutes (in one-second increments) and OFF. (10 seconds - 99 minutes 59 seconds for a 3800 Controller with VMD Open Loop Output Option - no OFF setting for this configuration.)
Derivative Time Constant:	00 seconds - 10 minutes in one-second increments.
ON/OFF Differential:	0.1% - 10% of span.

ENVIRONMENT**Reference Conditions**

- Ambient Temperature:	20°C ±2°C
- Supply Voltage:	120V or 240V ±1% 50/60Hz ±1%
- Thermocouple source resistance:	< 10Ω
- RTD (Pt100):	< 0.1Ω per lead, both leads equal.
- Relative Humidity:	60% - 70%

Operating Conditions

- Ambient Temperature:	0°C - +50°C (operating) -20°C - +60°C (storage)
- Supply Voltage:	193V - 264V @ 50/60Hz 100V - 132V @ 50/60Hz
- Maximum Source Resistance	
- Thermocouple:	< 1000Ω
- RTD (Pt100):	< 5Ω per lead (equal resistance in each lead).

PERFORMANCE

Reference Accuracy:	Typically, ±0.5% of span, ±1 lsd.
Temperature Stability:	< 0.015% of span for 1°C change in ambient temperature.
Cold Junction Compensation:	< 0.1°C change for 1°C change in ambient temperature.
Effect of Thermocouple Resistance:	< 0.1% of span error for resistance 0Ω - 100Ω.
Effect of RTD Lead Resistance:	< 0.1% of span error for 3Ω lead resistance.
Effect of Supply Voltage Change:	< ±0.1% of span error for supply voltage within specified limits.

GENERAL

Display:

Light-emitting diode (LED) display showing:

- * Four-digit seven-segment numeric display
- * 26 parameter legends

Front Panel Controls

Four pushbuttons:

- Auto/Manual Select
- Function Select
- Raise
- Lower

Dimensions

- Width: 48mm (1.89 in.)
- Height: 96mm (3.78 in.)
- Depth: 153mm (6.02 in.)
- Weight: 0.6kg (1.32 lb)

Power Consumption:

Approximately 3VA.

APPENDIX B PRODUCT CODES

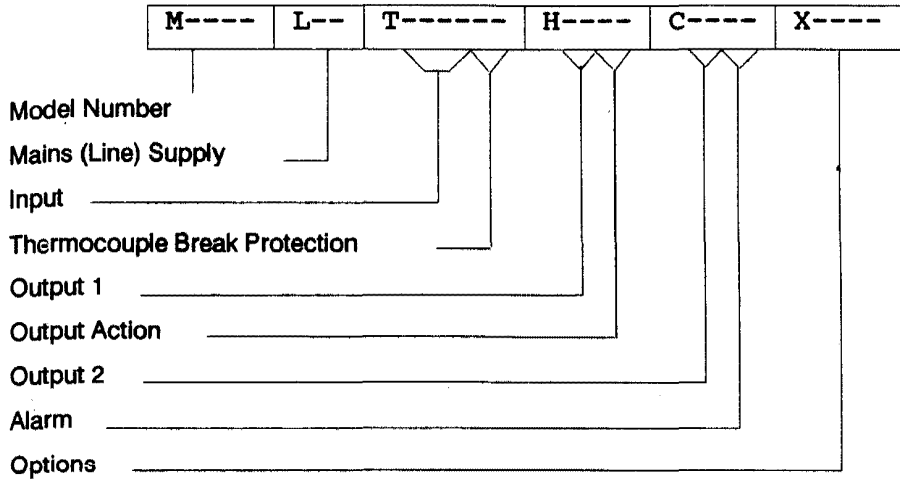

MODEL NUMBER

M3700 or M3800

MAINS (LINE) VOLTAGE

L01	200V/240V nominal @ 50/60Hz
L02	110V/120V nominal @ 50/60Hz
L04	24V nominal @ 50/60Hz

INPUT - TYPE AND RANGE

Thermocouple

T1127	R	0 - 1650°C	T1420	J	32 - 1400°F
T1128	R	32 - 3002°F	T1541	T	0 - 260°C
T1227	S	0 - 1650°C	T1542	T	32 - 500°F
T1228	S	32 - 3002°F	T1719	K	0 - 760°C
T1415	J	0 - 205°C	T1720	K	32 - 1400°F
T1416	J	32 - 401°F	T1723	K	0 - 1371°C
T1417	J	0 - 450°C	T1724	K	32 - 2500°F
T1418	J	32 - 842°F	T1983	B	100 - 1820°C
T1419	J	0 - 760°C	T1984	B	212 - 3308°F

Thermocouple Break Protection

- T---- Upscale break protection (standard)
- T----21 Downscale break protection
- T----22 No break protection

Three-wire Resistance Temperature Detector (RTD)

T2221	0 to +600°C	T2295	0.0 to +100.0°C
T2222	+32 to +1112°F	T2296	+32.0 to +212.0°F
T2229	+32 to +572°C	T2297	-200 to +205°C
T2230	-101.0 to +100.0°C	T2298	-328 to +401°F
T2231	-150.0 to +212.0°F	T7201	-101.0 to +300.0°C
T2251	0 to +300°C	T7202	-150 to +572°F

DC Linear Input

T4443	0 - 50mV	T4415	0.2 - 1.0V
T4449	10 - 50mV	T4445	0 - 5V
T4412	0 - 100mV	T4434	1 - 5V
T4416	20 - 100mV	T3413	0 - 20mA
T4444	0 - 1V	T3414	4 - 20mA

OUTPUTS**Output 1 (Normally reverse-acting)**

H10	Relay	H61*	DC Output 1V - 5V
H50	SSR Drive	H64*	DC Output 0V - 5V
H21*	DC Output 4mA - 20mA	H70**	VMD Open Loop Output
H24*	DC Output 0mA - 4mA		

* DC Output 2 is not available with DC Output 1.

** VMD Open Loop Output is available on Model 3800 Controllers only and the following restrictions apply:

- (a) Output 2 is not available if the VMD Open Loop Output is fitted.
- (b) The VMD Open Loop Output cannot be re-configured to any other output option; Controllers with any other output fitted cannot be re-configured to the VMD Open Loop Output.
- (d) The Self-Tune/Pre-Tune facilities are inoperative.

Output 1 Option:

H--31	Direct-Acting
-------	---------------

Output 2 (Action opposite to Output 1 i.e. normally direct-acting)

C00	Output 2 not fitted
C10	Relay
C50	SSR Drive
C21*	DC Output 4mA - 20mA
C24*	DC Output 0mA - 20mA
C61*	DC Output 1V - 5V
C64*	DC Output 0V - 5V

* DC Output 2 is not available with DC Output 1.

Alarms

C--50	Relay, high/low deviation (direct-acting)
C--51	Relay, high/low deviation (reverse-acting)
C--46	Band Alarm, relay ON if process variable inside band
C--47	Band Alarm, relay ON if process variable outside band
C--48	Relay, process alarm (direct-acting)
C--49	Relay, process alarm (reverse-acting)

OTHER OPTIONS

X06	RS485-compatible communications link for operation as a Slave Controller (With Option X06 fitted, it is possible to have Output 2 or Alarm Output fitted, but not both).
X69	Push-on blade terminals
X73	1/4 DIN to 1/8 DIN conversion plate.
X79	Remote Front Panel with 0.5m connecting cable
X74	Remote Front Panel with 2.0m connecting cable
X75	Remote Front Panel with 5.0m connecting cable
X76	Chassis Mounting Bracket for use with X74, X75 or X79
X04	Remote Set Point Input 0 - 5V
X05	Remote Set Point Input 4 - 20mA
X37	Remote Set Point Input 0 - 20mA
X38	Remote Set Point Input 1 - 5V
X0440	Remote Set Point Input 0 - 5V, permanently selected
X0540	Remote Set Point Input 4 - 20mA, permanently selected
X3740	Remote Set Point Input 0 - 20mA, permanently selected
X3840	Remote Set Point Input 1 - 5V, permanently selected
X12	Recorder Output 0 - 5V
X18	Recorder Output 0 - 20mA
X19	Recorder Output 4 - 20mA
X20	Recorder Output 1 - 5V

Alphabetical Index

A		L	
Alarm Types	4-13	Lower pushbutton	
Auto Pre-Tune Facility		Fast decrement rates	3-3
Restrictions in use	3-3	Function	3-2
Auto/Manual pushbutton		Use with VMD output, Manual Control	3-4
Function	3-2		
C		M	
Combo Scan message	5-5	Mains Supply Variants	2-5
Communications Link		Mounting Panel (Controller)	
Baud rate	5-1	Cut-out dimensions	2-1
Channel address selection	5-1	Maximum thickness	2-1
Data character format	5-1	Multiple mounting cut-out dimensions	2-1
Message format	5-3	Mounting Panel (Remote Front Panel)	
Message types	5-3	Cut-out dimensions	2-2
Restrictions in communicating	5-1		
Restrictions in use	5-1	P	
Controller/PCB Handling Precautions	2-3	Protection Network Component Values	2-12
D		R	
Dimensions (Remote Front Panel)		Raise pushbutton	
When panel-mounted	2-2	Fast increment rates	3-3
Dimensions (Controller)		Function	3-2
When panel-mounted	2-1	Use with VMD output, Manual Control	3-4
E		Recorder Output Scaling	
End of Message Character	5-4	Decimal point position	4-6
F		S	
Flashing Displays		Self-Tune Facility	
Cause	4-1	Restrictions in use	3-3
FUNC pushbutton		Self-Tune Routine	
Function	3-2	Activation of,	4-13
H		Set Up Mode	
Handling Precautions Recommended for PCBs	6-1	Automatic exit to User Mode	4-1, 4-13
		Start of Message Character	5-4
		V	
		Valve Motor Drive applications	
		Recommended restrictions, control action	4-10
		VMD Output with Interlock	2-9