

# Installation, operation & maintenance instructions

M317

September 2005

## Mobrey

### Magnetic Level Switch

SM\*1: General purpose models

SM\*2: Flameproof models

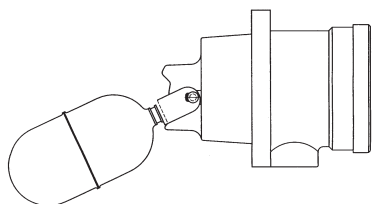

For instructions specific to ATEX Approved Flameproof Models in Hazardous Area Installations, refer to accompanying leaflet M317/SI

#### Storage & Handling

Mobrey magnetic level switches should be handled with care and respect at all times. They are level detection **instruments** and, whilst being of robust construction, should not be dropped or subjected to any mechanical abuse that could cause damage.

The switches should be stored on suitable racking in clean and dry conditions, and the factory packing and/or boxes should not be removed until the switch is ready for installation. The storage area should not experience ambient temperatures below 1°C, or above 60°C, and/or 70% humidity (RH).

These switches contain strong permanent magnets, so they should not be stored in close proximity to sources of electro magnetism or other strong magnets.

Switches in boxes may be stacked together without damage, but stacks must be such that the boxes are not crushed or damaged.

Mobrey switches have a shelf life in excess of 10 years provided the above precautions are followed.

When the switch is called for installation, it is essential that this manual is kept with the switch to guide the user in correct installation, resulting in a long and trouble free operation.

**This product contains no asbestos or other harmful material which require notification or controlled disposal.**

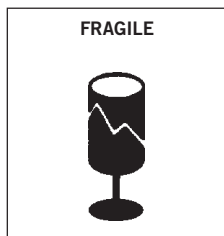

**mobrey**

www.mobrey.com



**EMERSON**  
Process Management

## Section 2 - Installation

SM\*2 flameproof models. Also refer to M317/SI

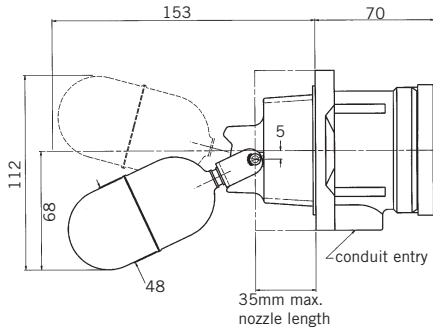

### Direct mounting level switches

(Direct into vessel).

Unpack the Mobrey magnetic level switch from its box and remove all packing pieces, tie strings and tape. The gasket supplied with this product must be handled with care to avoid damage. This switch contains strong permanent magnets: ferrous debris or particles may become attached to the float magnet. Always check the float magnet is clean before final installation.

The level switch should be positioned so that the float may move freely over its full travel and not foul the sides, bottom or top of the tank or the mounting boss or nozzle if so mounted. Positions where turbulence may be caused by agitators or by inlet connections should be avoided.

The plant should be clear of any loose materials or metallic particles which might accumulate round the float magnet and interfere with the operation of the switch. Where the liquid may contain sediment or solid particles, particular attention must be given to keeping these free of the float assembly.

### Switches in Pressurised Vessels

A studded pad is necessary where the switch is required to operate in a pressure vessel. See page 2-2 for flange and bolting data. Thread mounting switches should be installed into a suitable boss, using the 92mm square flange as spanner/wrench flats. Tighten to achieve a seal, using PTFE tape if necessary. Ensure that the final orientation of the switch is such that the float is free to move vertically up and down. Orientation is given by the word 'Top' stamped on the flange side.

Mobrey magnetic level switches have the type number stamped on a nameplate fixed either to the end cap or the switch body.

Variations to catalogue models are identified by a 7\*\*\*\*/\*\*\*\* type number.

The nearest standard production type number is also quoted on the equipment nameplate to allow identification of the relevant paragraphs in this manual.

The float unit carries a permanent magnet which is opposed magnetically to a similar magnet in the switch assembly.

The switch contacts are changed over with a snap action by magnetic repulsion between the magnets, acting across the wall of the switch body.

No intermediate 'off' position can be obtained.

### Mounting flange details

Mobrey 'M' switches have flat face flanges, and are supplied with non-asbestos or rubber gaskets. Details of the mating flange required for standard Mobrey flanges are shown below:-

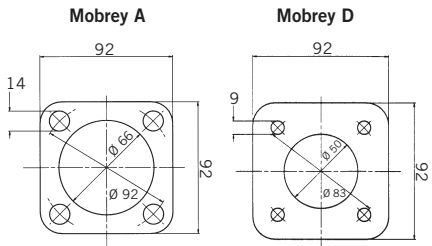

When mounted the switch body axis should be horizontal within two degrees either way. Mounting flange details are given above.

When fitted to an open tank or sump, not under pressure, flanged switches may be mounted through a hole cut in the tank and secured with bolts or studs. Mobrey 'companion' flanges are available to facilitate mounting - details below.

To facilitate mounting of Mobrey 'A' flange switches, the following mounting accessories are available :- Weld on pad J184

Backing flange for GRP tanks J863  
(Refer to installation instructions supplied with backing flange kit)

	A Flange	D Flange
Stud size	12mm	8mm
Projection	25mm	25mm

### Bolting Torque Details

If ordinary carbon steel or similar bolts are used the torques recommended are as shown right. If in doubt about your bolt/sealing application consult your engineering department or gasket manufacturer.

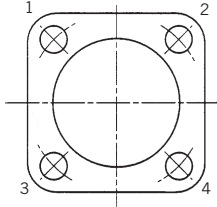

Min torques in Nm (lbf.ft) Max torque = min + 10%

Mobrey A	20 (15)
Mobrey D	5 (3)

Bolts should be lubricated with suitable grease.

Correct bolt tightening sequence :-

1. Torque in sequence to 30% of final torque.
2. Torque in sequence to 60% of final torque.
3. Torque in sequence to the final torque.
4. Re-torque the bolts to the final torque in a clockwise sequence.
5. If necessary, re-torque the bolts after 24 hours or one complete process cycle, whichever is the sooner.

Information in this section is to the best of our knowledge correct. Since conditions of use are beyond our control users must satisfy themselves that bolt/torques are suitable for the flange/process/conditions of the applications.

### Electrical Characteristics and Wiring Details

Rating	AC	DC (Res.)	DC (Ind.)
Max. voltage V	250	250	250
Max. current A	15	0.25	15mA

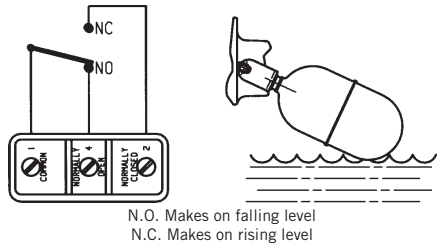

### Notes on Electrical Wiring and Connection

#### i) Connections:

- SMA\*: M20 conduit thread
- SMB\*: M20 conduit thread
- SMD\*: Pg 13,5 with cable gland
- SMN\*: 1/2" NPT conduit thread

NOTE: Flameproof models

Only suitable certified cable entry devices may be used to connect this equipment

#### ii) Direct starting of motors

Mobrey switches can be used for the direct starting of small motors (1/10HP) only.

For larger motors, switches should be used in series with the operating coils of relays, contactors or solenoid valves and fused separately.

#### iii) High temperatures

Suitable heat-resisting cable should be used where switch heads are subject to temperatures in excess of ambient.

#### iv) Earthing

It is recommended that the earthing terminal provided is used to earth the level switch, particularly when the switch is fitted to non-metallic or coated vessels or flanges.

### Operation

Once installed in accordance with section 2.0, the Mobrey magnetic level switch is ready for operation.

A test may be made by lifting the float by hand to check that the float moves freely and the relevant

alarm or pump control relays operate. On no account try to operate the float with a rigid rod which could cause damage to the float itself.

# Installation, operation & maintenance instructions

M317

September 2005

## Section 3 - Maintenance & Spares

### Maintenance

Mobrey magnetic level switches are designed for long and trouble free operation, provided regular routine maintenance is carried out in accordance with the recommendations below:-

- (1) Switch off electrical supply and isolate or drain down as necessary.
- (2) Remove level switch from tank or chamber.
- (3) Remove deposits of sludge, scale etc. Any tightness in the movement of the float assembly or the pivot pin should be investigated and corrected. Note: The float assembly is not removable from the switch head.
- (4) Remove any metallic particles adhering to the float magnet assembly by wiping with plasticine. Avoid contamination by swarf, etc, on benches and tools.
- (5) The gasket or sealing tape should be replaced and the switch installed in accordance with the installation instructions given in Section 2.

### To examine or replace internal switch assembly

- i) Switch off electrical supply
- ii) Unscrew end cover.

Note: On flameproof models, slacken off cover locking screw prior to unscrewing cover.

- iii) Disconnect wiring.
  - iv) Unscrew three screws retaining switch mechanism and withdraw switch mechanism.
  - v) Ensure that interior of switch body is clean and dry.
  - vi) Manually operate magnet on switch insert from side to side - do not handle roughly - and check that magnet returns to its natural position when released.
  - vii) Examine pivot points and check that they are free of dirt or contamination and do not hinder or restrict magnet movement.
  - viii) Replace switch mechanism and secure with three fixing screws.
- Warning: It is essential to ensure that no swarf or debris has become attached to the magnet or entered the switch body.
- ix) Re-connect electrical wiring
  - x) Check that cover seal is in good order - replace if necessary then re-fit the end cover. Re-tighten cover locking screw on flameproof models.

**If any parts require replacement, a complete internal switch mechanism must be fitted.**

### Spares

The spare/replacement switch mechanism for the Mobrey M switch is SK276.

Each Mobrey magnetic level switch has a set of recommended spare parts which are available from Mobrey Measurement at the address below, or from your local Mobrey Measurement appointed stockist. These genuine Mobrey Measurement spare parts are supplied in kit form so that all the relevant components and assemblies are included, ensuring fast and reliable servicing of the product.

Please contact Mobrey Measurement in the event of any difficulty in the installation, operation or maintenance of the product. A member of our spares and repairs department will be happy to assist.

Thank you for buying a Mobrey Measurement magnetic level switch. We are confident it will give you years of reliable and trouble free operation.

### Mobrey Measurement

158 Edinburgh Avenue,  
Slough, Berks, UK, SL1 4UE  
T +44 (0) 1753 756600  
F +44 (0) 1753 823589  
mobrey.sales@  
EmersonProcess.com  
www.mobrey.com

### Mobrey Inc

19408 Park Row, Suite 320,  
Houston, TX 77084 USA  
T +281 398 7890  
F +281 398 7891  
mobrey.sales@  
EmersonProcess.com  
www.mobrey.com



Mobrey SA-NV  
Mobrey Ltd  
Mobrey GmbH  
Mobrey SA  
Mobrey sp z o o  
Mobrey AB

Belgium	tel: 02/465 3879
China	tel: 021 6232 7972
Deutschland	tel: 0211/99 808-0
France	tel: 01 30 17 40 80
Polska	tel: 022 871 7865
Sverige	tel: 08-725 01 00