

## Performance Diaphragm Operated Pressure Difference Switches **300** Series

301 / 3 / 4  
381/4  
Issue I

- Precision stainless steel mechanism for arduous atmospheres and high humidity.
- Static pressure up to 250 bar (3500 psi).
- Set point adjustable over whole range against calibrated scale with tamperproof adjuster
- Weatherproof and Flameproof models EEx d IIC - ATEX.
- NACE MR-01-75 compatibility.
- Models for fixed switching differential, adjustable differential and HI-LO operation.
- Safety vented or blow out device as standard.
- Hermetically sealed microswitch option.
- ATEX and IECEX

### Performance **characteristics**

#### Enclosure

- IP66 Protection

#### Wetted parts options

- 316 Stainless Steel diaphragm. (standard)
- Nickel Alloy (Monel) suitable for NACE MR-01-75.

#### Standard Electrical ratings

- Refer to table 6

#### Process connection

- Rc ¼ (BSP), ¼ NPT Internal, ½ NPT Internal & ½ NPT External.

#### Unit weight

- Between 4.5kg – 9.7kg (9.9lb – 21.4lb)

#### Accuracy

- Set point repeatability  $\pm 1\%$  of span at 20 °C / 68 °F ambient.
- Scale accuracy  $\pm 3\%$  of full scale.



### Product **applications**

The 301 is suitable for a wide range of applications in many Industry sectors:

- Oil & Gas
- Chemical
- Petrochemical
- Refining
- Power
- Food Industry

The choice of models available ensures that the 301 is suitable for use in:

- Corrosive atmospheres
- Resistant to chemical attack

### How can we **help you?**

Delta Controls' range of reliable pressure and temperature measurement instruments can be customised to meet individual requirements. For technical advice or to discuss your application please contact us on +44 (0) 20 8939 3500

## Enclosure

### FINISH

All enclosures except Type A are finished in light grey epoxy resin paint. Special finishes to order.

### INTRINSIC SAFETY



Because of the low voltages and currency of I.S. circuits, we recommend using gold and/or sealed contacts.

**NOTE:** Enclosure Codes W & A with range BC, C6, E1 and E8 (BU, CP, E4, E7) have weather protection reduced to IP54. In the interests of reliability not all enclosures are available with all wetter parts materials. See Table 4.

Temperatures in Table 1 refer to limitations for certified enclosures. See **TECHNICAL DATA**.

TABLE 1



WEATHERPROOF ENCLOSURES	Code
<b>General Purpose</b> The basic enclosure is pressure die-cast in zinc alloy, offering weather protection not less than NEMA 4 + 13/IP66.	W
<b>For Aggressive Atmospheres</b> Investment cast enclosure in austenitic stainless steel with weather protection not less than NEMA 4X + 13/IP66.	A
<b>FLAMEPROOF ENCLOSURES CATEGORY 2 (ZONE 1)</b> <b>EExd IIC T6 (-60 to + 40°C), T4 (-60 to +80°C) II 2 G D</b> Gravity die-cast enclosure in aluminium-silicon alloy, certified to CENELEC EN50 014 and EN50 018. Suitable for outdoor use, IP66 / NEMA 4 	H
<b>IECEx Exd11C certified</b> to IEC 60079-0 and IEC60079-1	
<b>EExd IIC T6 (-60 to + 40°C), T4 (-60 to +80°C) II 2 G D</b> As Code H, but sand cast in high quality grey iron. 	K
<b>IECEx Exd11C certified</b> to IEC 60079-0 and IEC 60079-1	
<b>EExn ENCLOSURES CATEGORY 3 (ZONE 2)</b> <b>Type of Protection EExn II T6 (-20 to +40°C) II 3 G</b> As code 'W' but EExn to EN50021. Weatherproof to NEMA 4/IP66. <b>Limited switching facility (see table 6)</b>	N
As 'N' but with investment cast enclosure in austenitic stainless steel as 'A'.	O

## Models

Maximum working pressures are as follows:

**301, 303, 381**  
110 bar (1600 psi)

**304, 384**  
250 bar (3500 psi)

TABLE 2



	Code
<b>Fixed Switching Differential.</b> See Tables 10A & 10C. Basic model giving close, fixed switching differential using proprietary microswitch operated by high integrity stainless steel mechanism. Set point field adjustable over full range against calibrated scale. SPDT & DPDT options available.	301 304
<b>Adjustable Switching Differential.</b> (Wide Span) See Tables 10B & 10D. Falling set point adjustable against a calibrated scale. Rising reset point adjustable to increase switching differential by up to 50% of range.	303
<b>HI-LO Switching</b> (Adjustable Gap) See Tables 10A & 10C. Two individual set points and separate electrical circuits, with independent adjustment against calibrated scale.	381 384

## Electrical Entry

Adaptors are available for other popular thread sizes.

### Enclosures 'W' and 'N'

Standard option code 1 (22mm dia) is provided with a nylon 22/20 reducer and fibre washer suitable for a standard M20 cable gland and back nut. Option code 0 elbow adaptor is factory fitted. Adapter kits may also be provided retrospectively to fit at site if required. Ask for details. See diagrams for dimensions

### 'W' and 'N' SAFETY NOTE

If a metal cable gland is site fitted it must either be earthed locally or an earth/gland plate must be used to connect the body of the gland at the enclosure earthing point. Earth/gland plates can be provided either factory fitted or in kit form for site assembly. Ask for details

TABLE 3

	Code
Enclosure W & N: Clearance for 20mm (3/4 in) outside dia conduit.	1
Enclosures H, K & A: M20 x 1.5 ISO thread (direct).	0
Enclosures H & K: M20 x 1.5 ISO thread, dual entry.	5
Enclosures H & K: 3/4-NPT INT.	3
Enclosures H & K: 3/4-NPT INT. dual entry	6
Enclosure W: M20 x 1.5 elbow adaptor.	0
Enclosure N: M20 x 1.5 straight adaptor (Approved).	0

## Material of Wetted Parts

TABLE 4

	Code
316 stainless steel diaphragm. All other wetted parts fully austenitic 300 series stainless steel. PTFE and Nitrile seals.	I
Nickel Alloy (Monel) diaphragm. All other wetted parts fully austenitic 300 series stainless steel. PTFE and Nitrile seals.	J
For wetted parts required to conform with Sour Gas or Sour Crude applications as laid down in NACE standard MR-01-75	L
Nickel Alloy (Monel) diaphragm and other wetted parts. PTFE and Viton seals. (NACE)	Q
316 Stainless Steel diaphragm. All other wetted parts fully austenitic 300 Series stainless steel. P.T.F.E. and Viton seals	R

## Setting Ranges

TABLE 5

$P_{max}$  = maximum working pressure

The instruments will sustain, without loss of performance, a continuous forward over pressure equal to the maximum static/line pressure and/or full vacuum.

**NOTE:** For pressure difference switches maximum working pressure ( $P_{max}$ ) and maximum static/line pressure mean the same.

Maximum static pressure applied in the reverse direction (i.e. to LO port with HI port to atmosphere) will be contained without failure. The diaphragm will however have been distorted, leading to a degradation of performance and a shortening of the service life. For applications where regular reversals of pressure are inevitable, a special engineering facility is available.

### MODELS 301/303/381

bar	$P_{max}$	psi	RANGE			Code		
			mbar/bar	Code	in H <sub>2</sub> O/psi			
110 OR (250)		1600 (3500)	-12.5 to +12.5	BC*	-5.0 to +5.0	BU*		
			3 to 25	C6	1 to 10	CP		
			5 to 120	E1	2 to 50	E4		
			50 to 350	E8	1 to 5	E7		
			0.1 to 1.5	G5	1 to 20	GP		
			0.2 to 4	J0*	2 to 60	J3*		
			0.7 to 7	M2*	10 to 100	M8*		
			1.5 to 15	P8*	20 to 200	PK*		
			SEE MODELS					

### MODELS 304/384

bar	$P_{max}$	psi	RANGE			Code		
			mbar/bar	Code	in H <sub>2</sub> O/psi			
110 OR (250)		1600 (3500)	-12.5 to +12.5	0C*	-5.0 to +5.0	0U*		
			3 to 25	06	1 to 10	0P		
			5 to 120	01	2 to 50	04		
			50 to 350	08	1 to 5	07		
			0.1 to 1.5	G5	1 to 20	GP		
			0.2 to 4	J0*	2 to 60	J3*		
			0.7 to 7	M2*	10 to 100	M8*		
			1.5 to 15	P8*	20 to 200	PK*		
			SEE MODELS					

\*Ranges BC/0C/BU/0U, J0/J3, M2/M8 and P8/PK not available on models 303, 381 and 384

## Switching Options

**TABLE 6**

A much wider variety of switching options can be engineered to customer's requirements for Model 301 switches, including heavy DC, manual latching, pneumatic output etc. On models 303, 381 & 384 only the switching options specified can be supplied. Please consult our engineers for further information.

<b>Model 301, 304</b>									
<b>UL/CSA Rating (RESISTIVE) §SEE NOTE</b>	IEC 947-5-1/EN 60947-5-1 Rating							Contact	Code
	Designation & Utilization Category	Rated operational current I <sub>e</sub> (A) at rated operational voltage U <sub>e</sub>	U <sub>i</sub>	U <sub>imp</sub>	VA Rating				
					Make	Break			
5 Amps @ 110/250V AC Light Duty for AC only	AC14 D300	0.6/0.3A @ 120/240V AC	250V	0.8kV	432	72	SPDT DPDT	00 01	
	DC13 R300	0.22/0.1A @ 125/250V DC			28	28			
5 Amps @ 110/250V AC & 2 Amps @ 30V DC General purpose precision	AC14 D300	0.6/0.3A @ 120/240V AC	250V	0.8kV	432	72	SPDT DPDT	02 03	
	DC13 R300	0.22/0.1A @ 125/250V DC			28	28			
1 Amp @ 125V AC & <b>§100mA @ 30V DC</b> gold alloy contacts for low voltage switching	1 A @ 125 VAC RESISTIVE (IEC 1058-1/EN 61058-1)						SPDT DPDT	04 05	
<b>§ 5 Amps @ 110/250V AC &amp; 5 Amps @ 30V DC</b> Environmentally sealed.	AC14 D300	0.6/0.3A @ 120/240V AC	250V	0.5kV	432	72	SPDT* DPDT*	08 09	
	DC13 R300	0.22/0.1A @ 125/250V DC			28	28			
§ 1 Amp @ 30V AC & 30V DC Environmentally sealed with gold contacts	AC14 E150	0.3A @ 120V AC	125V	0.5kV	216	36	SPDT* DPDT*	0G 0H	
5 Amps @ 250V AC and 2 Amps @ 30V DC Hermetically sealed. Gold plated silver contacts.	AC14 D300 DC13 R300	0.6/0.3A @ 120/240V AC 0.22/0.1A @ 125/250V DC	250V	0.5kV	432 28	72 28	SPDT DPDT	H2 H3†, H6‡	
† 2 Single pole, double throw, simultaneous falling under pressure									
‡ 2 Single pole, double throw, simultaneous rising under pressure.									
<b>Model 303</b>									
5 Amps @ 110/250V AC & 2 Amps @ 30V DC General purpose precision	AC14 D300	0.6/0.3A @ 120/240V AC	250V	0.8kV	432	72	SPDT DPDT	02 03	
	DC13 R300	0.22/0.1A @ 125/250V DC			28	28			
1 Amp @ 125V AC & <b>§100mA @ 30V DC</b> gold alloy contacts for low voltage switching	1 A @ 125 VAC RESISTIVE (IEC 1058-1/EN 61058-1)						SPDT DPDT	04 05	
<b>Model 381, 384</b>									
5 Amps @ 110/250V AC Light Duty for AC only	AC14 D300	0.6/0.3A @ 120/240V AC	250V	0.8kV	432	72	SPDT	20	
	DC13 R300	0.22/0.1A @ 125/250V DC			28	28			
5 Amps @ 110/250V AC & 2 Amps @ 30V DC General purpose precision	AC14 D300	0.6/0.3A @ 120/240V AC	250V	0.8kV	432	72	SPDT	22	
	DC13 R300	0.22/0.1A @ 125/250V DC			28	28			
1 Amp @ 125V AC & <b>§100mA @ 30V DC</b> gold alloy contacts for low voltage switching	1 A @ 125 VAC RESISTIVE (IEC 1058-1/EN 61058-1)						SPDT	24	
<b>§ 5 Amps @ 110/250V AC &amp; 5 Amps @ 30V DC</b> Environmentally sealed.	AC14 D300	0.6/0.3A @ 120/240V AC	250V	0.5kV	432	72	SPDT*	28	
	DC13 R300	0.22/0.1A @ 125/250V DC			28	28			
§ 1 Amp @ 30V AC & 30V DC Environmentally sealed with gold contacts	AC14 E150	0.3A @ 120V AC	125V	0.5kV	216	36	SPDT*	2G	
5 Amps @ 250V AC and 2 Amps @ 30V DC Hermetically sealed. Gold plated silver contacts.	AC14 D300 DC13 R300	0.6/0.3A @ 120/240V AC 0.22/0.1A @ 125/250V DC	250V	0.5kV	432 28	72 28	SPDT	H4	
<p>The electrical rating is dependent on the microswitch fitted to the instrument. The electrical ratings defined by each approval that the microswitch complies with and is shown on the product nameplate, ie UL/CSA, or IEC. It should be noted that the instrument must be used within the electrical rating specified from the approval you require. This table lists the actual IEC ratings against the Designation &amp; Utilization Category marked on the nameplates. In the absence of any verification by UL/CSA the microswitch § manufacturer's rating is stated in <b>italics and bold</b>. <b>If in doubt seek guidance from the factory.</b></p> <p><b>NOTE:</b> For low energy circuits e.g. 30V and up to 100mA, we recommend using gold alloy contact switches.</p> <p>U<sub>i</sub> = rated insulation voltage      U<sub>imp</sub> = rated impulse withstand voltage across contacts.</p> <p>*Suitable for use with EExn Enclosures (Code N)</p>									

## Process Connection

Other thread specifications and sizes are available without using adaptors.

Adaptors are available for applications where their use is permitted.

TABLE 7



	Code
Rc 1/4 (1/4 BSP tr INT) to ISO 7/1	A
1/4 – 18NPT INT	F
1/2 – 14NPT INT	H
1/2 – 14NPT EXT	J

## Options & Treatments

Combinations available, apply for details.

TABLE 8



	Code
Tropicalisation High humidity environment	01
Marine and Offshore Saline atmosphere or salt spray	02
Ammonia Process (wetted) parts and construction suitable for atmospheric ammonia.	03
Oxygen Service 2: Process (wetted) parts are cleaned for oxygen.	04
Oxygen Service3: Process and non-process parts are cleaned for use with oxygen.	05
Stainless Steel Pipe Mounting Bracket Permits local 2" pipe work to be utilised for mounting the instrument.	10
Tagging - Variety of tagging methods are available	APPLY FOR DETAILS
Applies when – no option is required and selection is made from special engineering.	00

## Special Engineering

TABLE 9



FEATURE	Code
Please consult Delta sales engineering for special requirements.	TBA

## Performance Data

**TABLE 10**

### Bar Units (SI)

**TABLE 10A: 1 & 2.**  
**MODELS 301, 304, 381, 384**  
**FIXED SWITCHING**  
**DIFFERENTIAL**

MODEL 381/384: The switching differential on each point may be up to 1.5 times that of Table 10A & 10C. Care must be exercised, therefore, in specifying high differential switches on sensitive ranges, or set point separation less than 3 times switching differential.

**MODEL 301 & (381)**

**mbar units**

**TABLE 10A:1**

Range Code	Range mbar / bar	SPDT OPTIONS					DPDT OPTIONS				
		00 (20)	02 (22)	04 (24)	08/0G (28/2G)	H2 (H4)	01	03	05	09 / 0H	H3 / H6
BC	-12.5 to +12.5	2	6	2	5	4	4	8	4	10	20
C6	3 to 25	2	6	2	5	4	4	8	4	10	20
E1	5 to 120	4	12	4	10	12.5	8	16	8	25	50
E8	50 to 350	10	30	10	20	17.5	20	40	20	30	60
G5	0.1 to 1.5	50	150	50	90	125	100	200	100	115	230
J0	0.2 to 4	100	300	100	200	300	200	400	200	250	500
M2	0.7 to 7	200	600	200	250	400	400	800	400	300	600
P8	1.5 to 15	300	900	300	500	600	600	1200	600	600	1200

**MODEL 304 & (384)**

**mbar units**

**TABLE 10A:2**

Range Code	Range mbar / bar	SPDT OPTIONS					DPDT OPTIONS				
		00 (20)	02 (22)	04 (24)	08/0G (28/2G)	H2 (H4)	01	03	05	09 / 0H	H3 / H6
0C	-12.5 to +12.5	2	6	2	5	4	4	8	4	10	20
06	3 to 25	2	6	2	5	4	4	8	4	10	20
01	5 to 120	4	12	4	10	12.5	8	16	8	25	50
08	50 to 350	10	30	10	20	17.5	20	40	20	30	60
G5	0.1 to 1.5	50	150	50	90	125	100	200	100	115	230
J0	0.2 to 4	100	300	100	200	300	200	400	200	250	500
M2	0.7 to 7	200	600	200	250	400	400	800	400	300	600
P8	1.5 to 15	300	900	300	500	600	600	1200	600	600	1200

**TABLE 10B**  
**MODEL 303**  
**ADJUSTABLE SWITCHING**  
**DIFFERENTIAL**

**MODEL 303**

**mbar units**

**TABLE 10B**

Range Code	Range mbar / bar	SPDT OPTIONS				DPDT OPTIONS			
		02		04		03		05	
		From	To	From	To	From	To	From	To
C6	3 to 25	8	25	8	25	12	25	12	25
E1	5 to 120	15	120	15	120	22	120	22	120
E8	50 to 350	50	350	50	350	75	350	75	350
G5	0.1 to 1.5	150	750	150	750	225	750	225	750

### PSI Units

**TABLE 10C: 1 & 2**  
**MODELS 301, 304, 381, 384**  
**FIXED SWITCHING**  
**DIFFERENTIAL**

Switching differentials in.H<sub>2</sub>O/psi.

**MODEL 301 & (381)**

**PSI units**

**TABLE 10C:1**

Range Code	Range in.H <sub>2</sub> O / psi	SPDT OPTIONS					DPDT OPTIONS				
		00 (20)	02 (22)	04 (24)	08/0G (28/2G)	H2 (H4)	01	03	05	09 / 0H	H3 / H6
BU	-5.0 to +5.0	0.8	2.4	0.8	2	1.6	1.6	3.2	1.6	4	8
CP	1 to 10	0.8	2.4	0.8	2	1.6	1.6	3.2	1.6	4	8
E4	2 to 50	1.6	4.9	1.6	4	5	3.2	6.4	3.2	10	20
E7	1 to 5	0.15	0.45	0.15	0.3	0.25	0.3	0.6	0.3	0.45	0.9
GP	1 to 20	0.7	2.2	0.7	1.3	1.8	1.5	2.9	1.5	1.7	3.3
J3	2 to 60	1.5	4.4	1.5	2.9	4.3	2.9	5.8	2.9	3.6	7.3
M8	10 to 100	2.9	8.7	2.9	3.6	5.8	5.8	11.6	5.8	4.4	8.7
PK	20 to 200	4.4	13	4.4	7.5	8.7	8.7	17.5	8.7	8.7	17.5

Due to manufacturing tolerances the figures quoted in these tables are for guidance only. Should the differential be critical for specific applications our engineers should be consulted prior to ordering.

Flameproof models may be up to 2 times higher depending on the range. Should the differential be critical for specific applications our engineers should be consulted prior to ordering.

**TABLE 10D**  
**MODEL 303**  
**ADJUSTABLE SWITCHING**  
**DIFFERENTIAL**

**MODEL 304 & (384)**

**PSI units**

**TABLE 10C:2**

Range Code	Range in.H <sub>2</sub> O / psi	SPDT OPTIONS					DPDT OPTIONS				
		00 (20)	02 (22)	04 (24)	08/0G (28/2G)	H2 (H4)	01	03	05	09 / 0H	H3 / H6
0U	-5.0 to +5.0	0.8	2.4	0.8	2	1.6	1.6	3.2	1.6	4	8
0P	1 to 10	0.8	2.4	0.8	2	1.6	1.6	3.2	1.6	4	8
04	2 to 50	1.6	4.9	1.6	4	5	3.2	6.4	3.2	10	20
07	1 to 5	0.15	0.45	0.15	0.3	0.25	0.3	0.6	0.3	0.45	0.9
GP	1 to 20	0.7	2.2	0.7	1.3	1.8	1.5	2.9	1.5	1.7	3.3
J3	2 to 60	1.5	4.4	1.5	2.9	4.3	2.9	5.8	2.9	3.6	7.3
M8	10 to 100	2.9	8.7	2.9	3.6	5.8	5.8	11.6	5.8	4.4	8.7
PK	20 to 200	4.4	13	4.4	7.5	8.7	8.7	17.5	8.7	8.7	17.5

**MODEL 303**

**PSI units**

**TABLE 10D**

Range Code	Range in.H <sub>2</sub> O / psi	SPDT OPTIONS				DPDT OPTIONS			
		02		04		03		05	
		From	To	From	To	From	To	From	To
CP	1 to 10	3.2	10	3.2	10	4.8	10	4.8	10
E4	2 to 50	5	48	5	48	8.9	48	8.9	48
E7	1 to 5	0.75	5	0.75	5	1.1	5	1.1	5
GP	1 to 20	2.2	11	2.2	11	3.5	11	3.5	11

## Technical Specifications

### ACCURACY

Set point repeatability  $\pm 1\%$  of full scale at 20°C ambient.

Scale accuracy  $\pm 3\%$  of full scale.

### AMBIENT TEMPERATURE RANGE

All models are suitable for operating within a range of ambient temperature from -25 to +60°C (-13 to +140°F).

Special build available for temperatures down to -60°C (-76°F)

### MAXIMUM PROCESS TEMPERATURE

Subject to appropriate installation practice, the component parts will withstand +60°C (+140°F), for process temperatures up to +120°C (+248°F) order **WETTED PARTS**. Code R (Table 4) and for higher temperatures refer to **SPECIAL ENGINEERING**.

ENCLOSURES	
'W' & 'N'	4.5kg/9.9lb
'A' & 'O'	6.4kg/13.8lb
'H'	5.9kg/13.0lb
'K'	9.7kg/21.4lb
For range C6/CP add	0.4kg/0.9lb
For series 304 add	2.3kg/5.1lb

### ELECTRICAL CONNECTIONS

#### Terminal Block

Cable entry is to a non-pinching terminal block made of a non-hygroscopic thermosetting plastic, suitable for cables up to 2.5mm<sup>2</sup>/14AWG.

#### Earthing/Grounding

An earthing stud is provided inside all weatherproof enclosures, adjacent to the entry. External earthing is standard on flameproof versions. Safety note see Table 3.

#### Dielectric Strength

The electrical assembly is capable of withstanding \*2kV between live parts and earth/ground and 500V between open contacts.

\*1.2kV for micro switch Codes H2, H3, H4 and H6. Refer to Table 6.

#### Electrical Entry

Standard options are listed in Table 3. Other threads can be accommodated by adaptors. Dual entry available, see Table 3.

### OPTIONAL EXTRAS

#### Chemical Seals

Chemical seals of our own or proprietary manufacture can be fitted when required.

#### Mounting

##### Position/Location/Installation

Vertical as shown, IN DIMENSIONS, taking care to avoid siting in locations that transmit excessive shock or vibration. For further advice contact our engineers.

#### Pollution degree (EN60947-5-1)

All products are suitable for use in pollution degree 3. For extreme conditions where condensation may readily form, then sealed contacts should be used. See Table 6 codes 08/09, 0G/0H, 2G, 28, H2/H3/H4/H6.

**Electrical Isolation** – These products are not suitable for electrical isolation. Always isolate circuit separately to carry out any electrical work.

## Approvals

### INTRINSIC SAFETY

Because of the low voltages and currents of intrinsically safe circuits, we recommend using gold contacts. Refer to Table 6.

#### CENELEC/ATEX II 2 G D

Certified to CENELEC EN50 014 and EN50 018.

For use in Zone 1 hazardous areas EEx d IIC T6 (-60° to +40°C)  
T4 (-60° to +80°C)



Enclosure Codes H and K and all models (see Table 1)

Certificate number BAS01ATEX2426X

IECEX APPROVAL for use in Zone 1 hazardous areas

Exd IIC certified to IEC 60079-0 and IEC 60079-1

Cert No. IECEXITS04 0006X

## Dimensions

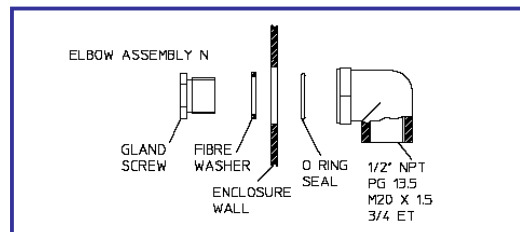
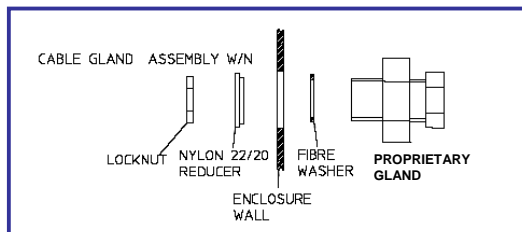

# Dimensions

All dimensions mm (inches)

**NOTE:** Dimensions refer to ranges E1/E4 (Models 301, 303, 381); G5 (Models 304, 384), and upwards Ranges C6/CP/BC/BU (Models 301 303, 381); E8/E7 (Models 304, 384), and below, have flanges 25mm (0.98in) larger in diameter.

The distance between pressure connections is therefore increased by 25mm (0.98in) and the stand-off from wall mounting by 12.5mm (0.49in).

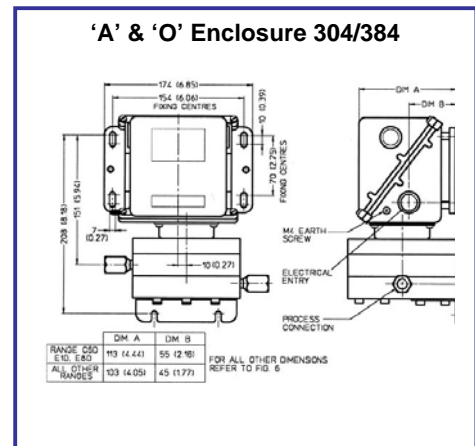
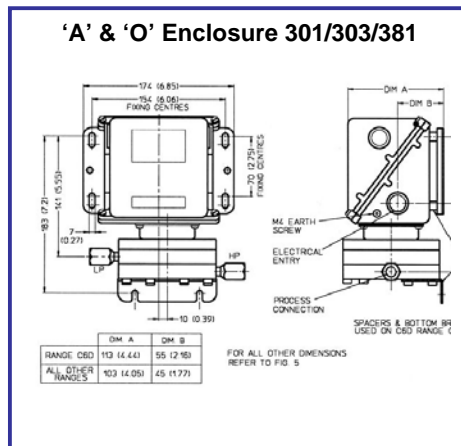
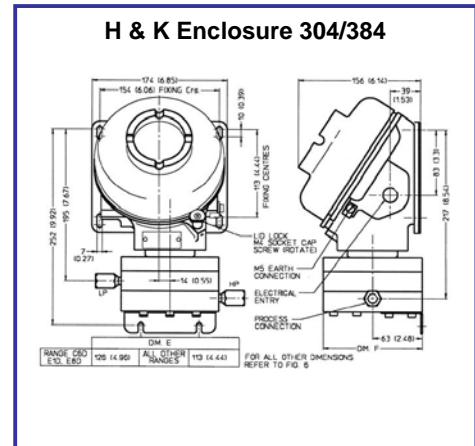
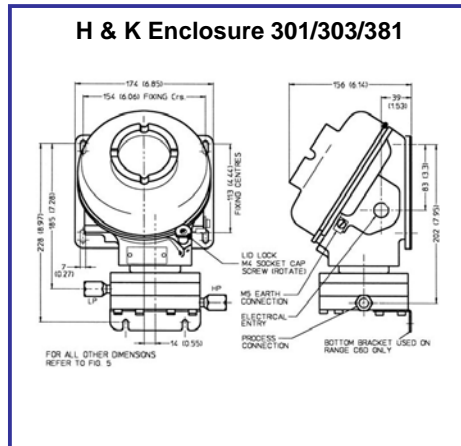
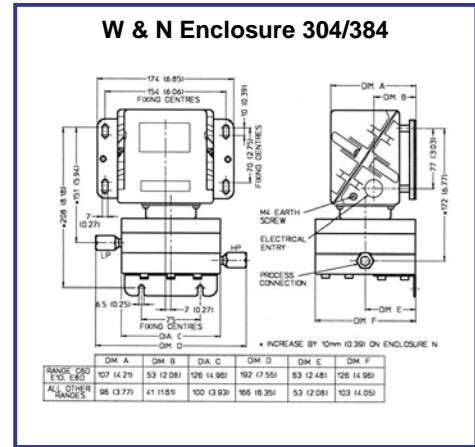
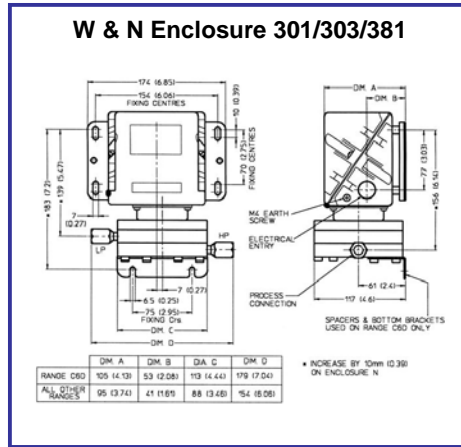

In the interest of development and improvement Delta Controls Ltd, reserves the right to amend, without notice, details contained in this publication. No legal liability will be accepted by Delta Controls Ltd for any errors, omissions or amendments.



Delta Controls Limited

Island Farm Avenue, West Molesey, Surrey KT8 2UZ, UK.

T+44 (0)20 8939 3500 F+44 (0)20 8783 1163 [E sales@delta-controls.com](mailto:sales@delta-controls.com) [W www.delta-controls.com](http://www.delta-controls.com)



FM00720